

SIMADO GBR42 System Manual

*Version 1
September 2008*



Matrix Telecom Pvt. Ltd.

Corporate Office:

394-GIDC, Makarpura,
Vadodara-390 010, India

Tel. : +91 265 2630555

Fax : +91 265 2636598

E-mail: Info@MatrixTeleSol.com

URL: www.MatrixTeleSol.com

Factory:

39-GIDC, Waghodia-391 760

Dist. Vadodara, India

Tel. : +91 2668 263172/73

Fax : +91 2668 262631

E-mail: Support@MatrixTeleSol.com

Documentation Information

This is a general documentation and it covers many models with different specifications. A particular product may not support all the features and facilities described in the documentation.

Matrix Telecom reserves the right to revise information in this publication for any reason without prior notice. Information in this documentation may change from time to time. Matrix Telecom makes no warranties with respect to this documentation and disclaims any implied warranties. While every precaution has been taken in preparation of this system manual, Matrix Telecom assumes no responsibility for errors or omissions. Neither is any liability assumed for damages resulting from the use of the information contained herein.

Matrix Telecom reserves the right without prior notice to make changes in design or components of the equipment as engineering and manufacturing may warrant.

Neither Matrix Telecom nor its affiliates shall be liable to the purchaser of this product or third parties for damages, losses, costs or expenses incurred by purchaser or third parties as a result of: accident, misuse or abuse of this product or unauthorized modifications, repairs or alterations to this product or failure to strictly comply with Matrix Telecom's operating and maintenance instructions.

All rights reserved. No part of this system manual may be copied or reproduced in any form or by any means without the prior written consent of Matrix Telecom.

Contents

Section 1: Introduction	5
Welcome	7
Packing List	9
Warranty Statement	10
Introducing the System	13
Protection and Safety	15
Configuring the System	16
Getting Started	24
Section 2: Features and Facilities	31
Allowed and Denied Lists	33
Automatic Number Translation	38
Call Detail Recording (CDR)	43
Call Duration Control (CDC)	47
Call Proceeding Tone	49
Call Processing in SIMADO GBR42	52
Call Progress Tones	56
Calling Party Number Based Routing	59
Clock Synchronization	63
Communication Port	65
Daylight Saving Time Adjustment	67
Default the Configuration	72
Dialed Number Based Routing	73
Emergency Number Dialing	78
Fixed Dialing	82
International Mobile Equipment Identity (IMEI)	85
ISDN-An Introduction	86
Jeeves	94
Mobile Port Parameters	96
Network Selection	102
NT Port Parameters	106
Number Lists	113
Programming the System	115
Real Time Clock (RTC)	116
Remote Programming	118
Returned Calls to Original Callers (RCOC)	119
Routing Group	124

<i>Routing Type</i>	131
<i>SIM PIN</i>	136
<i>Software Version/Revision Display</i>	138
<i>System Event Log</i>	139
<i>System Parameters</i>	143
<i>TE Port Parameters</i>	146
<i>Time Table</i>	159
Section 3: Appendices	163
<i>Appendix A : Technical Specifications</i>	165
<i>Appendix B : System Commands</i>	167
<i>Appendix C: Regulatory Information</i>	172
Index	174

Section 1: Introduction

Welcome

Welcome to the world of telecom solutions from Matrix and thanks for purchasing a Matrix product.

We want you to get the maximum performance from our product. If you run into technical difficulties, we are here to help. But please consult this system manual first.

If you still can't find the answer, gather all the information or questions that apply to your problem and, with the product close to you, call your dealer. Matrix dealers are trained and ready to give you the support you need to get the most from your Matrix product. In fact, most problems reported are minor and can be easily solved over the phone.

- ***The words GSM and Mobile are used interchangeably in the system manual.***
- ***The words SIMADO GBR42 System and Gateway are used interchangeably in the system manual.***

In addition, technical consultation is available from Matrix engineers every business day. We are always ready to give advice on application requirements or specific information on installation and operation of our products.

The system manual is divided in following sections:

Section 1: Introduction

Section 2: Features and Facilities

Section 3: Appendices

We suggest first time users to read this system manual in the following sequence.

- Section 1
- Section 2 (in the sequence given below):
 - ISDN-An Introduction 86
 - Default the Configuration 72
 - Communication Port 65
 - Programming the System 115

- Software Version/Revision Display 138
- Time Table 159
- Number Lists 113
- Allowed and Denied Lists 33
- Automatic Number Translation 38
- Call Processing in SIMADO GBR42 52
- Routing Group 124
- Routing Type 131
- Real Time Clock 116
- Daylight Saving Time Adjustment 67
- NT Port Parameters 106
- TE Port Parameters 146
- Mobile Port Parameters 96
- Returned Calls to Original Callers 119
- Fixed Dialing 82
- Calling Party Number Based Routing 59
- Dialed Number Based Routing 73
- Call Duration Control 47
- Call Detail Recording 43
- Call Progress Tones 56
- Emergency Number Dialing 78
- IMEI 85
- Network Selection 102
- SIM PIN 136
- Jeeves 94

Packing List

The ideal sales package for SIMADO GBR42 is as mentioned below:

Sr.	Accessories	Qty.
01	SIMADO GBR42	1
02	System Manual	1
03	Adaptor 12 VDC, 2 Amp.	1
04	Wall Mounting Nails	2
05	Warranty Card Set	1
06	Support Card	1
07	COM Port Cable (RS232C)	1
08	RJ45 Cables	2
09	SIMADO GBR42 CD	1
10	Mounting Template	1
11	Antenna with Cable	1

- Please make sure that these components are present.
- In case of short supply or damage detection, contact the source from where you have purchased the system.

=X=X=

Warranty Statement

Matrix Telecom Pvt. Ltd. (Matrix) warrants to its consumer purchaser for any of its products to be free of defects in material, workmanship and performance for a period of 15 months from date of manufacturing or 12 months from the date of installation which ever is earlier.

During this warranty period, Matrix will at its option, repair or replace the product at no additional charge if the product is found to have manufacturing defect. Any replacement product or part/s may be furnished on an exchange basis, which shall be new or like-new, provided that it has functionality at least equal to that of the product being replaced. All replacement parts and products will be the property of Matrix. Parts repaired or replaced will be under warranty throughout the remainder of the original warranty period only.

This limited warranty does not apply to:

1. Products that have been subjected to accident, natural disaster, misuse, modification, tampering, faulty installation, lack of reasonable care, repair or service in any way that is not contemplated in the documentation for the product or if the model or serial number has been altered, tampered with, defaced or removed.
2. Products which have been damaged by lightning storms, water or power surges or which have been neglected, altered, used for a purpose other than the one for which they were manufactured, repaired by customer or any party without Matrix's written authorization or used in any manner inconsistent with Matrix's instructions.
3. Products received improperly packed or physically damaged.
4. Products damaged due to operation of product outside the products' specifications or use without designated protections.

Warranty valid only if:

- Primary protection on all the ports provided.
- Mains supply is within limit and protected.
- Environment conditions are maintained as per the product specifications.

Warranty Card:

- When the product is installed, please return the warranty card with:
 - Date, signature and stamp of the customer.
 - Date, signature and stamp of the channel partner.
- Matrix assumes that the customer agrees with the warranty terms even when the warranty card is not signed and returned as suggested.

The Purchaser shall have to bear shipping charges for sending product to Matrix for testing/rectification. The product shall be shipped to the Purchaser at no-charge if the material is found to be under warranty. The Purchaser shall have to either insure the product or assume liability for loss or damage during transit.

Matrix reserves the right to waive or make any changes in its warranty policy without giving any notice.

If Matrix is unable to repair or replace, as applicable, a defective product which is covered by Matrix warranty, the Matrix shall, within a reasonable time after being notified of the defect, refund the purchase price of the product provided the consumer purchaser returns the product to Matrix.

In no event will Matrix be liable for any damages, including lost profits, lost business, lost savings, downtime, or delay, labor, repair or material cost, injury to person, property, or other incidental or consequential damages arising out of use of or inability to use such product, even if Matrix has been advised of the possibility of such damages or losses, or for any claim by any other party.

Except for the obligations specifically set forth in this Warranty Policy Statement, in no event shall Matrix be liable for any direct, indirect, special, incidental or consequential damages whether based on contract or any other legal theory and where advised of the possibility of such damages.

Neither Matrix nor any of its distributors, dealers or sub-dealers makes any other warranty of any kind, whether express or implied, with respect to Matrix products. Matrix and its distributors, dealers or

sub-dealers specifically disclaim the implied warranties of merchantability and fitness for a particular purpose.

This warranty is not transferable and applies only to the original consumer purchaser of the Product. Warranty shall be void if the warranty card is not completed and registered with Matrix within 30 days of installation.

All legal course of action subjected to Vadodara (Gujarat, India) Jurisdiction only.

Introducing the System

ALERT !

At every power up of the system or re-registration of the GSM modules with the GSM network, the GSM modules take approx. 3 minutes to get registered with the network. Hence, during this period it is possible that the Outgoing calls made from the system may get routed through BRI-TE port/s of the system. However, once the GSM modules (ports) get registered with the network, the calls are routed through GSM ports as configured by the Administrator.

- Matrix product SIMADO GBR42 is a versatile gateway using GSM and ISDN technology.
- It is a GSM-ISDN (BRI) Gateway which interfaces two different networks: (a) GSM and (b) ISDN-BRI. The calls can be routed from GSM Network to ISDN BRI through GSM ports of the gateway or can be routed from ISDN-BRI lines to GSM Network, through GSM ports of the gateway. For the gateway each port can be an Originating port or a Terminating port.
- The Matrix gateway is mainly designed for connection with ISDN PBX. It enables direct calling to the GSM network. It can also be used with standard phone set connected via TA (Terminal Adapter).
- The basic function is the voice-mode: for outgoing and incoming calls, and the Matrix gateway is fully equipped with all functions necessary for this application.
- The gateway can be connected as BRI-NT or as BRI-TE.
- The Gateway supports four GSM ports (SIM) and two ISDN-BRI ports. Each port can be configured as TE/NT. Thus four BRI channels are available.

Main Benefits of using Matrix Gateway:

- By using with ISDN PBX, call to mobile networks can be directly performed from ISDN Phone benefiting from low call tariff, eliminating landline charges.
- Thanks to the advanced and powerful Least Cost Router the Gateway can select the cheapest possible route for the calls taking into consideration the dialed number prefix.

- Call Detail Recording, for keeping records of calls history.
- Using RCOG features, callers from the gateway can get their called party's call on their own phone station if they could not call them while they were busy.
- The Gateway supports two options for system programming:
 - Programming with phone
 - Programming with Windows based GUI makes all the features easy to operate.

SIMADO GBR42 Photograph:



=X=X=

Protection and Safety

This chapter explains the general safety precautions and precautions during installation.

Safety Precautions:

- Unplug this product from the wall outlet before cleaning. Do not use liquid cleaners or aerosol cleaners. Use a dry and soft cloth for cleaning.
- Operate this product with proper supply voltage. If you are not sure about supply voltage, contact authorized dealer. It is advisable to give proper, stabilized power.
- Do not allow anything to rest on the power cord of product or AC-DC Adapter.
- Do not switch ON the GFX11 near the medical apparatuses to avoid interference. Keep minimum of 0.5m distance between antenna and pace maker.
- Do not switch ON the GFX11 aboard of a plane.
- Rules for prohibition based on RF energy radiation applies to GFX11 also like other mobile telephones. It may disturb the function of TV sets, radio sets and PC.
- **Warning!** The Antenna used for this equipment must be installed to provide a separation distance of at least 20 cm from all persons and must not be co-located with any antenna.
- Unplug this product from the wall outlet and contact qualified service personnel under the following conditions:
 - a) When the power supply cord or plug is damaged or frayed.
 - b) If liquid has been spilled into the product.
 - c) If the product has been exposed to rain or water.
 - d) If the product has been dropped or the cabinet has been damaged.

Installation Precautions:

- Do not install at places where sulfuric gases are produced and in areas where there are thermal springs, etc. because it may damage the equipment or contacts.
- Do not install at dusty places or places where water or oil may come into contact with the system.

=X=X=

Configuring the System

The SIMADO GBR42 can be configured for different applications to interface with GSM network, ISDN network, Terminal Equipment or ISDN-PBX.

This chapter includes following sections for using GBR42:

- Hardware configuration
- Applications for gateway

Hardware Configuration

Depending on the requirement, each BRI Port can be configured in TE/NT mode. It is possible to feed power to the terminal equipments connected to the BRI port (configured in NT mode) from the Gateway. Also proper termination on the connection, made between the Gateway and the ISDN terminals is required. Following section gives information about the same.

BRI Port can be configured either in TE mode or NT mode as per the table given below (**refer Note B**).

Mode	Jumper position for Port 2				Jumper position for Port 1			
	J2	J3	J4	J5	J9	J10	J11	J12
NT Mode	BC	BC	BC	BC	BC	BC	BC	BC
TE Mode	AB	AB	AB	AB	AB	AB	AB	AB

Jumpers J2, J3, J4, J5 and J9, J10, J11, J12 are on the main board. Default, jumper position is NT mode for hardware port 1 and hardware port 2.

The BRI Port (when configured in NT mode) can be configured to feed power to the terminal equipments connected to it using the jumpers mentioned in the table given below. Power can be fed on Tx and Rx wires as well as on separate pair of wires (**refer Note B**)

Description	J1	J2
To feed power on Tx and Rx wires (Phantom power)	A-B	A-B
To feed power on separate pair of wires	B-C	B-C
No Power to be fed to the terminal equipment	Open	Open

Jumpers J1 and J2 are on BRI Module of each port.

The termination of 100 Ohms can be provided on the BRI Port using following table: **(refer Note A)**

Description	J3	J4
To insert 100 Ohm Termination	A-B	A-B
To remove 100 Ohm Termination	B-C	B-C

Jumpers J3 and J4 are on BRI Module of each port.

Notes:

• **Note A:**

- Termination of 100 Ohms should be inserted in following cases:
 1. When the BRI port is configured in NT mode.
 2. When the BRI port is configured in TE mode and connected in Point-to-point configuration as shown in figure.

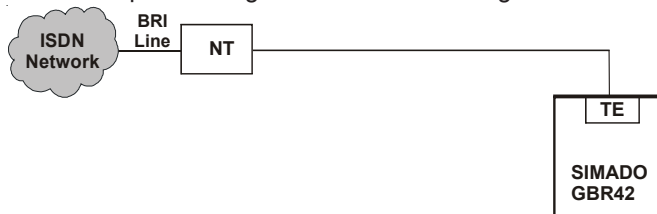

3. When the BRI port is configured in TE mode and connected as last terminal on the 'S0' bus (Multi-point configuration) as shown in figure.

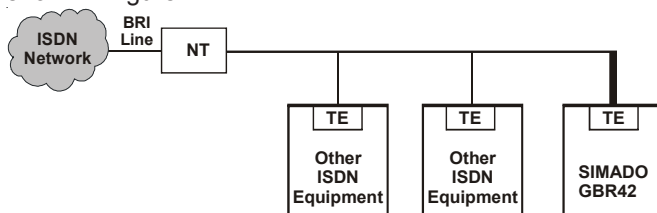

4. Termination need not be inserted in case 2 and 3 above, if the 'S0' bus itself supports Terminating resistors.
5. Termination need not be inserted if GBR42 (configured in TE mode) is connected as any 'Terminal' other than the last 'Terminal' on the 'S0' bus (Multi-point configuration).

- **Note B:**

- Number of ISDN terminals that can be connected on the BRI port configured in NT mode depends on the power consumed by the ISDN terminals. Maximum power that can be provided on one BRI port is 50mA. However, from signaling point of view maximum 8 terminals can be connected on the BRI port configured in NT mode. Hence, if the terminal equipments do not consume power from the BRI port (configured in NT mode) of the 'SIMADO GBR42', maximum 8 terminals can be connected to it.

- **Programming TE/NT mode**

Follow the steps mentioned below to change NT or TE mode:

- Assign port hardware ID to 'None' for each port in NT & TE configuration parameters.
- Program port hardware ID as per the user requirement.
- System will restart automatically. Now BRI port is programmed as per user's requirement.
- Default hardware ID, for BRI (NT) and BRI (TE) software port are as shown below:

Port Type	Software Port	Hardware ID
BRI NT	1	1
BRI TE	1	Null
BRI NT	2	2
BRI TE	2	Null

Thus for 'GBR21' configuration (2-GSM port, 1- BRI port), BRI (NT) will be considered as default port for interfacing with PBX.

- Ensure that, jumper setting is as per the Port Type, programmed.

Procedure to default SE Password

Follow the steps mentioned below to default the SE password:

- Switch OFF the system
- Locate a mini jumper 'J18' on the main PCB.
- Put the jumper in A-B position.
- Switch ON the system.
- Wait for 10 seconds after reset sequence of LED.
- Switch OFF the system.
- Restore the jumper in its original position (B-C).
- Switch ON the system.
- Now the SE password will be defaulted to '1234'.

Application for Gateway

Various applications are explained with following cases:

- Standalone with one TE and one NT.
- Standalone with both NT ports.
- Connecting ISDN PBX of NT port.
- Using BRI line of ISDN PBX for Gateway.
- Connecting ISDN PBX at one TE port.
- Connecting ISDN PBX at both TE ports.

The SIMADO GBR42 supports following applications:

Case 1: SIMADO GBR42 Standalone

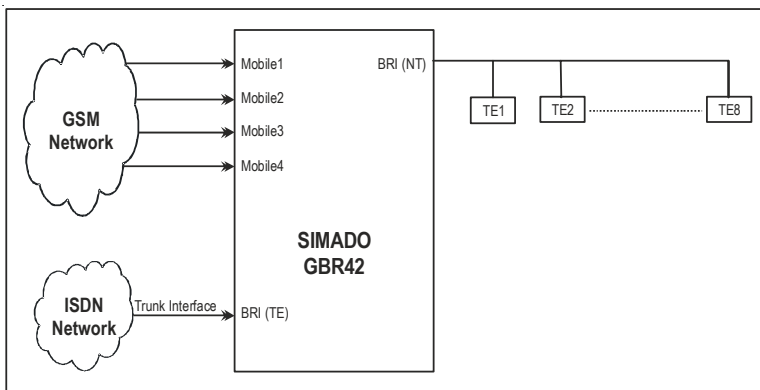

In this application eight ISDN phones can be connected at NT port of the SIMADO GBR42.

Call from the ISDN phone is routed to its destination via TE port or Mobile Port as per the logic used in call routing.

Case 2: SIMADO GBR42 Standalone

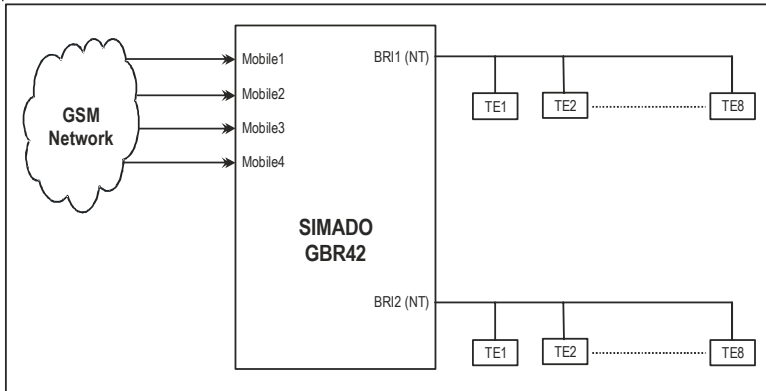

In this application total sixteen ISDN phones are connected at two NT ports of the Gateway.

Call from the ISDN phone is routed to its destination via Mobile Port which depends upon the logic used for call routing.

Case 3: SIMADO GBR42 PBX (BRI NT to PBX BRI TE)

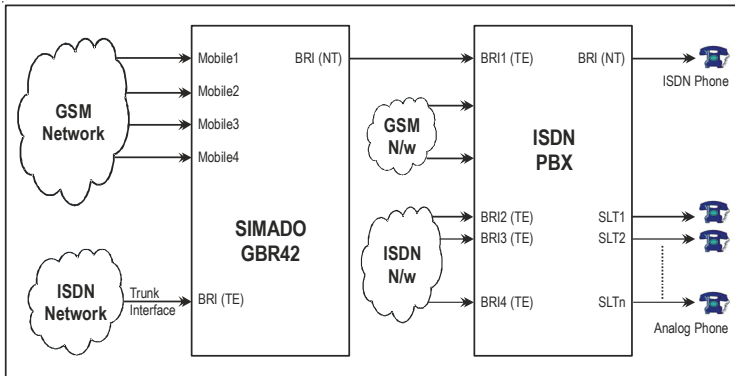

In this application calls either from Analog Phone or ISDN Phone are routed to SIMADO GBR42 when BRI1 (TE) port of the PBX is selected for outgoing path. The routing to mobile or TE port is as per the call routing logic of GBR42.

Case 4: SIMADO GBR42 PBX (BRI NT to PBX BRI TE)

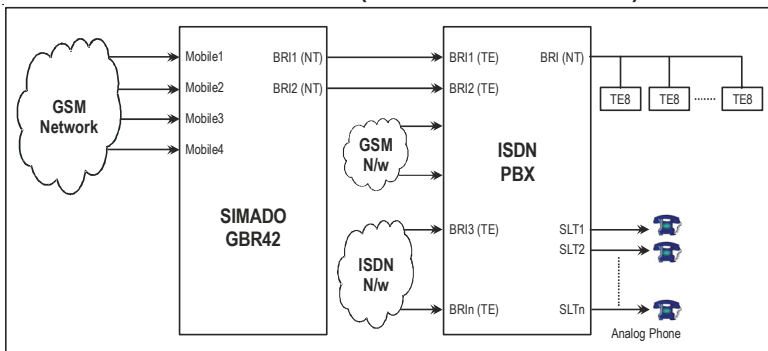

In this application calls either from Analog Phone or ISDN Phone is routed to SIMADO GBR42 when BRI1 (TE) port or BRI2 (TE) of the PBX is selected for outgoing path and the routing to a mobile port is as per the call routing logic.

Case 5: SIMADO GBR42 (BRI TE to PBX BRI NT)

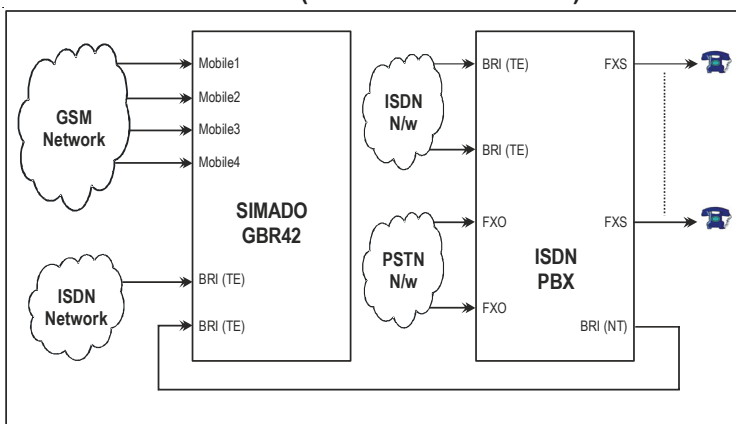

In this application calls from Analog Phones are routed to SIMADO GBR42 when BRI (NT) port of the PBX is selected for outgoing path and routing to GSM or TE port is as per the routing logic programmed.

Case 6: SIMADO GBR42 (BRI TE to PBX BRI NT)

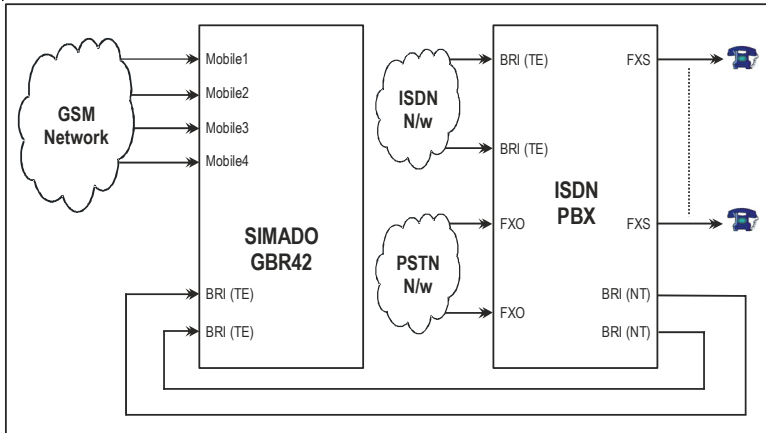

In this application calls from Analog Phones are routed to SIMADO GBR42 when BRI (NT) ports of the PBX are selected for outgoing path and routing to GSM port is as per the routing logic programmed.

Card Configuration:

The SIMADO GBR42 consists of:

1. GSM Interfaces = 4 (1 to 4 GSM modules).
2. BRI-ISDN Interfaces = 2.
3. LEDs = 9.

The LEDs

The SIMADO GBR42 supports 9 LEDs.

Out of which 4 dual colour LEDs are for Mobile Port, 1 LED for power 'ON' indication and 4 LEDs are for four BRI channels. Mobile port LEDs signify various events during Network communication cycle. Please refer the topic '[Getting Started](#)' for more details.

Relevant Topics:

1. [Allowed and Denied Lists](#) 33
2. [Call Processing in SIMADO GBR42](#) 52
3. [Routing Type](#) 131
4. [Routing Group](#) 124
5. [Getting Started](#) 24

-
6. Returned Calls to Original Callers (RCOC) 119
 7. Default the Configuration 72
 8. Programming the System 115
 9. NT Port Parameters 106
 10. TE Port Parameters 146
 11. Jeeves 94

=X=X=

Getting Started

- Unpack the box. Get satisfied with the contents and the condition of all the parts.
- Place the system at the suitable site.
- Check the voltage at the power point from where the supply is to be given to the system.

How to connect the BRI line?

- Most of the Service Providers provide the NT1 along with the BRI line.
- At the Customer's Premises, the BRI line is terminated on the NT1. The S/T interface of the NT1 is connected to BRI port of the system. This is shown in the figure given below.
- **Any BRI port can be configured as NT or TE with jumper setting on the card. 4-BRI channels are available.**

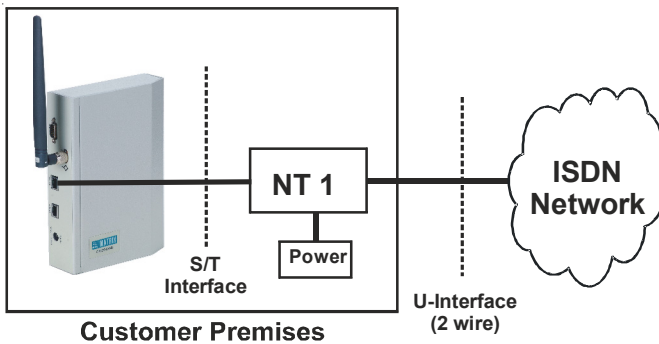

How to use Mobile Port?

- 4-GSM modules are mounted on the card and antenna connectors are combined into a single splitter where the antenna is connected.
- The antenna connector is provided on front panel to connect an external antenna with cable, attached with it.
- The SIM card is inserted like normal cell-phone. To use any mobile port, ensure that SIM is inserted, registered with network and enabled by proper programming.

Connection of gateway is described in two parts:

- Station Connection.
- BRI, Antenna and Mobile Port Connection.

At the end of chapter the dimensional detail is provided to help user for selecting the site of installation.

Station Connection:

- ISDN PBX can be connected with the gateway, analog telephones or ISDN phones as shown in [Configuring the System](#) for initiating calls or for incoming calls.
- ISDN phone can be connected to BRI, if configured as NT.

Following figure explain connection to other ports:

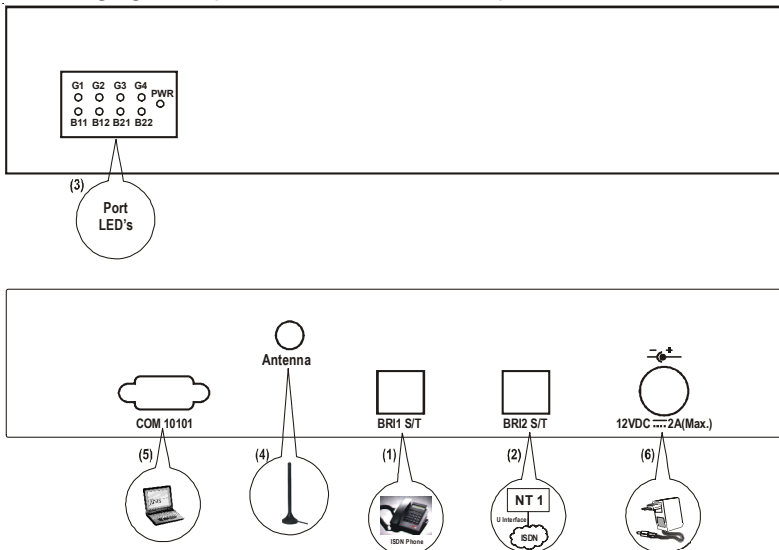

1. BRI1 S/T

- This port is hardware configured as NT port. Connect RJ45 cable from the BRI port to ISDN Phone.

2. BRI2 S/T

- This port is hardware configured as TE port. Connect BRI line subscribed from ISDN service provider with unique MSN number

and range of DDI numbers. The cable is connected through terminal adapter supplied by the service provider.

3. SIM Installation and LED

- Open the top cover of the gateway to install the SIM card.
- To get registered with GSM Network, insert at least one SIM card in the holder and lock it. This will activate one mobile port. Maximum four SIM cards can be inserted. Thus four mobile ports are available. LED's G1 to G4 indicates GSM port status corresponding to four SIM cards. LED B11 and B12 indicate status of two channels for BRI1 port and LED B21 and B22 indicates the status of two channels for BRI2 port.

4. Antenna

- Connect SMA connector of the cable, attached with antenna, to the Antenna port of the gateway. The cable is long enough, for user's convenience.

5. COM Port

- Connect RS232 cable from PC to COM Port of the gateway. This is required to get CDR reports or to program the system using Jeeves, a Windows based programming software. The pin connector for the cable is shown in the figure on next page.

6. 12 VDC

- Ensure supply voltage from power point is 90-265VAC 47-63Hz. Connect the DC power to the Gateway through the adaptor, supplied with the product LED 'PWR' will glow.

RJ-45 connector wiring:

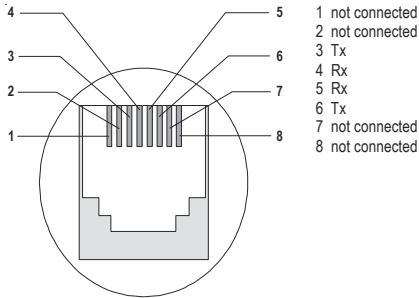

Connector wiring for TE interface

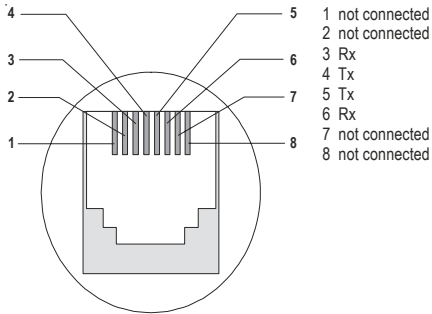

Connector wiring for NT interface

Connection of the ISDN GSM Gateway to a PC via RS232C Cable

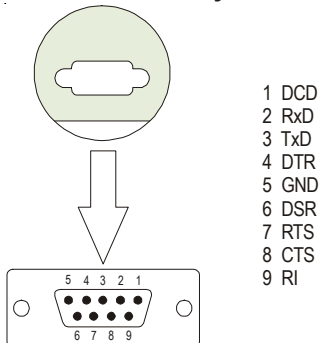

Before switching ON install the SIM card as mentioned below:

SIM PIN

Before switching ON the gateway, install the SIM card as mentioned below:

- Whenever the SIM PIN request is received from the module, the system will send the SIM PIN stored in the configuration to the module. Hence it is necessary that the SIM PIN in the SIM card and in the system is same.
- If required the parameters, 'SIM PIN' and 'SIM PIN at Power On flag' can be changed in the SIM card by removing the SIM card from the gateway, inserting it into the mobile handset and changing it from mobile handset.
- User should enable the 'SIM PIN at power ON' parameter in the SIM card to protect the SIM card that is inserted in the system from being mis-used.
- Now if SE tries to change the SIM PIN, on receipt of command for SIM PIN change, the system will first send the command to the module. If the 'SIM PIN at Power On flag' is enabled in the SIM card, the change would be effective.
- If 'SIM PIN at Power ON flag' is disabled in the SIM card, the change would not be effective. User can know this change in the SIM PIN by downloading the SIM PIN page of 'Jeeves'.
- Hence, the 'SIM PIN at Power ON flag' in the SIM card must be enabled. Otherwise, SIM PIN will not be changed using the command for 'Changing SIM PIN'.

Important Points:

- Ensure that the SIM PIN in the SIM card and in the system is same. By default, SIM PIN for all the ports of the system is 1234.
- To protect the SIM card that is inserted in the system from being mis-used, the customer is recommended to enable 'SIM PIN at Power ON' parameter in the SIM card.
- Ensure that the 'SIM PIN at Power On' parameter in the SIM card is enabled to change the SIM PIN.

Switching ON

- Switch ON the power for Adaptor. The system will take about 1-2 minutes to reset.

- The network communication cycle during resetting is explained below:
 - On completion of the reset sequence, the card starts communicating with the network.
 - The card checks for the events during this cycle and the error is displayed by the LEDs. For example, if SIM PIN faulty/Network absent is detected, it indicates that, GSM module could not log on to the network.
 - LED Indications during the normal functioning of the system will be as per following table:

Event	Color	Cadence in ms (1 cadence is of 3000 msec)
Port Disable	-	LED Off
Port Idle	-	LED Off
Port Active (Note1)	RED	Continuous ON
Ring Event	GREEN	400 On-200 Off-400 On-200 Off
Speech	GREEN	Continuous ON
GSM Initialization	ORANGE	200 On-200 Off-200 On-200 Off-200 On-200 Off-200 On-200 Off- 200 On-1200 Off (5 Blinks)
PUK required	ORANGE	200 On-200 Off-200 On-200 Off-200 On-200 Off-200 On-1600 Off (4 Blinks)
SIM PIN faulty	ORANGE	200 On-200 Off-200 On-200 Off-200 On-2000 Off (3 Blinks)
SIM Absent	ORANGE	200 On-200 Off-200 On-2400 Off (2 blinks)
Network Link Down	ORANGE	200 On-2800 Off (1 Blink)

Note1: All states other than Ring and Speech

Programming the System

This system provides many useful features. Program the system as per your requirement. For more details on requirements for programming the system, please refer to topics '[Call Proceeding in SIMADO GBR42](#)' and '[Programming the System](#)'.

SIMADO GBR42 Mechanical Dimension:

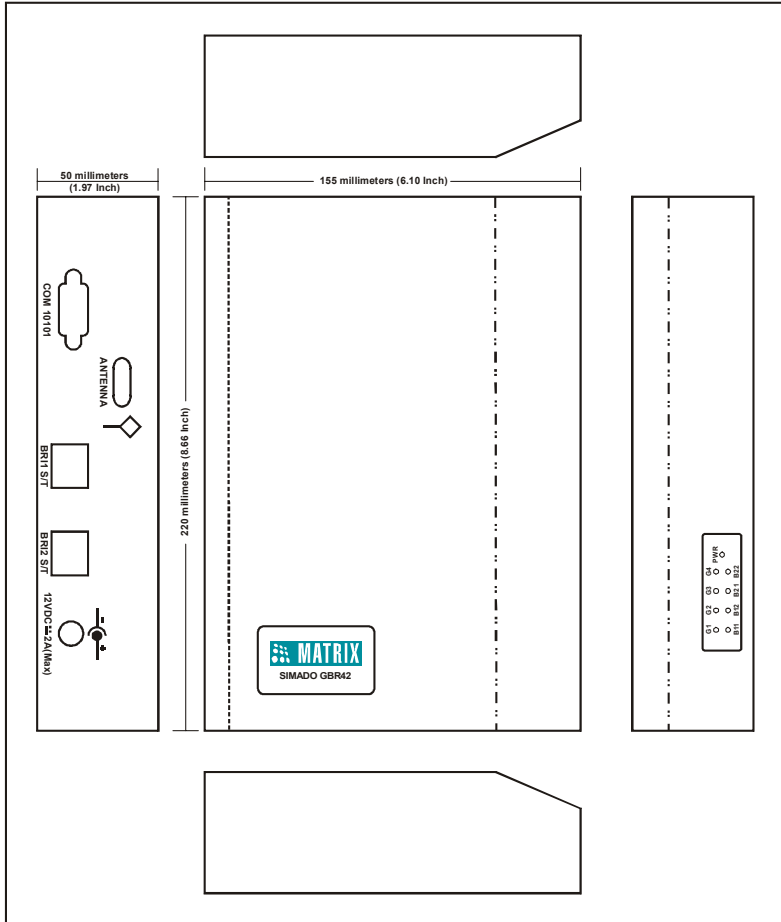

Relevant Topics:

- 1. Protection and Safety 15
- 2. Configuring the System 16
- 3. Jeeves 94
- 4. Communication Port 65

=X=X=

Section 2: Features and Facilities

Allowed and Denied Lists

What's this?

- The SIMADO GBR42, supports a feature by which it can prevent selected numbers to be dialed out, known as Allowed and Denied Lists. The feature should be enabled for the port.
- Allowed and Denied Number Lists are a group of number.

How it works?

- Number lists are used for this feature—one number list for allowed numbers and one for denied numbers for each port.
- This feature can be enabled/disabled on each port
- If this feature is disabled on a port, then all types of numbers are allowed as Called Party Numbers for all calls originating on that port
- If this feature is enabled on a port, then following logic will apply on every call originating on that port:
 - If the Called Party Number matches only with a number of the Allowed Number List assigned to the source port then the number is processed further.
 - If the Called Party Number matches only with a number of the Denied Number List assigned to the source port then the number is not processed further. The caller gets Error Tone in this case.
 - If the Called Party Number matches with a number of both Allowed and Denied Number Lists assigned to the source port, then the number is processed further.
 - If the Called Party Number does not match with any number from both Allowed and Denied Lists assigned to the source port, then the number is processed further.
- The logic is applied only on the port on which the call originates
- The application of Allowed/Denied Numbers is independent of the routing logic.

Number list looks as given below:

Loc. Index/No. List Index	01	02	03	04	05-23	24
01	Number String (16 digits)					
:						
16						

How to program?

- Step 1:** To enable/disable the allowed/denied number feature for Mobile Port using command **221**.
- Step 2:** To assign an allowed number list to a Mobile Port using command **222**.
- Step 3:** To assign a denied number list to a Mobile Port using command **223**.
- Step 4:** To enable/disable the allowed/denied number feature for TE Port using command **224**.
- Step 5:** To assign an allowed number list to a TE Port using command **225**.
- Step 6:** To assign a denied number list to a TE Port using command **226**.
- Step 7:** To enable/disable the allowed/denied number feature for NT Port using command **227**.
- Step 8:** To assign an allowed number list to a NT Port using command **228**.
- Step 9:** To assign a denied number list to a NT Port using command **229**.

Step 1

Use following command to enable/disable the allowed/denied number feature for Mobile Port:

221-Mobile Port-Code-#*

Where,

Mobile Port is from 1 to 4.

Code	Meaning
0	Disable
1	Enable

By default, Allowed/Denied number feature for Mobile Port is Disabled.

Step 2

Use following command to assign an allowed number list to a mobile port:

222-Mobile Port-List Number-#*

Where,

Mobile Port is from 1 to 4.

List Number is from 01 to 16.

By default, Number List = 01 is assigned to all mobile ports.

Step 3

Use following command to assign a denied number list to a mobile port:

223-Mobile Port-List Number-#*

Where,

Mobile Port is from 1 to 4.

List Number is from 01 to 16.

By default, Number List = 06 is assigned to all Mobile Ports.

Step 4

Use following command to enable/disable the allowed/denied number feature for TE Port:

224-TE Port-Code-#*

Where,

TE Port is from 1 to 2.

Code	Meaning
0	Disable
1	Enable

By default, Allowed/Denied number feature for TE Port is Disabled.

Step 5

Use following command to assign an allowed number list to a TE port:

225-TE Port-List Number-#*

Where,

TE Port is from 1 to 2.

List Number is from 01 to 16.

By default, Number List = 01 is assigned to all TE ports.

Step 6

Use following command to assign a denied number list to a TE port:

226-TE Port-List Number-#*

Where,

TE Port is from 1 to 2.

List Number is from 01 to 16.

By default, Number List = 06 is assigned to all TE ports.

Step 7

Use following command to enable/disable the allowed/denied number feature for NT Port:

227-NT Port-Code-#*

Where,

NT Port is from 1 to 2.

Code	Meaning
0	Disable
1	Enable

By default, Allowed/Denied number feature for NT Port is Disabled.

Step 8

Use following command to assign an allowed number list to a NT port:

228-NT Port-List Number-#*

Where,

NT Port is from 1 to 2.

List Number is from 01 to 16.

By default, Number List = 01 is assigned to all NT Ports.

Step 9

Use following command to assign a denied number list to a NT port:

229-NT Port-List Number-#*

Where,

NT Port is from 1 to 2.

List Number is from 01 to 16.

By default, Number List = 06 is assigned to all NT Ports.

Example:

Program the gateway such that a phone user at NT1 port is not allowed to dial some mobile numbers.

-
- 122-08-#*** (Clear number list 08)
121-08-01-98-#* (Mobile number 98 programmed in list 08)
121-08-02-93-#* (Mobile number 93 programmed in list 08)
121-08-03-94-#* (Mobile number 94 programmed in list 08)
229-1-08-#* (Assign list 08 as denied number list to NT1)

Relevant Topic:

1. Number Lists 113

=X=X=

Automatic Number Translation

What's this?

- This feature translates the called party numbers received from the Call processing logic to a number compatible to the port on which it is to be dialed out by the Gateway.
- For e.g. suppose the Gateway is so programmed that all the calls made within the telecom circle (Commonly called 95 calls) are routed through the Mobile port. Now when you make a call to a number, say '952668263172', the Call Handling logic of the Gateway determines a Mobile port on which this number should be dialed. But this number string is invalid for the GSM network.
- Hence the logic is required to translate this dialed number to a valid number before it is dialed by the system. Thus the dialed number string will be translated to '912668263172' by using this feature, called Automatic Number Translation (ANT).

How it works?

- Number Lists are used in this feature. There are two Number Lists assigned per port viz. Dialed Number List and Substitute Number List.
- The Dialed Number List contains numbers to be matched with the Called Party Number
- The Substitute Number List contains numbers used to replace the numbers or parts of numbers that match with the corresponding entry in the Dialed Number List
- This feature can be enabled and disabled on each port
- If enabled, then the Called Party Number is processed on the Destination Port chosen for the call and the number in the corresponding Index of the Substitute Number List will be dialed out.
- If this feature is disabled on a port, then the Called Party Number is always dialed out as it is.

For example, suppose the caller dials 952668263172 then number 912668263172 should be dialed out by the system so that it can be dialed out from the mobile port. Then two number list can be programmed as shown below.

Dialed-number list:

Index	Dialed String/Substring
01	95
02	

Substitute number list:

Index	Substitute String
01	91
02	

These two lists are assigned to a port from where the number is to be dialed out.

How to program?

- Step 1:** To enable/disable the ANT feature for mobile port using command **621**.
- Step 2:** To assign a dialed number list to a mobile port using command **622**.
- Step 3:** To assign a substitute number list to a mobile port using command **623**.
- Step 4:** To enable/disable the ANT feature for TE port using command **624**.
- Step 5:** To assign a dialed number list to a TE port using command **625**.
- Step 6:** To assign a substitute number list to a TE port using command **626**.
- Step 7:** To enable/disable the ANT feature for NT port using command **627**.
- Step 8:** To assign a dialed number list to a NT port using command **628**.
- Step 9:** To assign a substitute number list to a NT port using command **629**.

Step 1

Use following command to enable/disable the ANT feature for Mobile Port:

621-Mobile Port-Code-#*

Where,

Mobile Port is from 1 to 4.

Code	Meaning
0	Disable
1	Enable

By default, ANT number feature for Mobile Port is Disabled.

Step 2

Use following command to assign a dialed number list to a Mobile port:

622-Mobile Port-List Number-#*

Where,

Mobile Port is from 1 to 4.

List Number is from 01 to 16.

By default, Number List = 06 is assigned to the Mobile Port.

Step 3

Use following command to assign a substitute number list to a Mobile Port:

623-Mobile Port-List Number-#*

Where,

Mobile Port is from 1 to 4.

List Number is from 01 to 16.

By default, Number List = 06 is assigned to the Mobile Port.

Step 4

Use following command to enable/disable the ANT feature for TE Port:

624-TE Port-Code-#*

Where,

TE Port is from 1 to 2.

Code	Meaning
0	Disable
1	Enable

By default, ANT number feature for TE Port is Disabled.

Step 5

Use following command to assign a dialed number list to a TE Port:

625-TE Port-List Number-#*

Where,

TE Port is from 1 to 2.

List Number is from 01 to 16.

By default, Number List = 06 is assigned to the TE Port.

Step 6

Use following command to assign a substitute number list to a TE Port:

626-TE Port-List Number-#*

Where,

TE Port is from 1 to 2.

List Number is from 01 to 16.

By default, Number List = 06 is assigned to the TE Port.

Step 7

Use following command to enable/disable the ANT feature for NT Port:

627-NT Port-Code-#*

Where,

NT Port is from 1 to 2.

Code	Meaning
0	Disable
1	Enable

By default, ANT number feature for NT Port is Disabled.

Step 8

Use following command to assign a dialed number list to a NT Port:

628-NT Port-List Number-#*

Where,

NT Port is from 1 to 2.

List Number is from 01 to 16.

By default, Number List = 06 is assigned to the NT Port.

Step 9

Use following command to assign a substitute number list to a NT Port:

629-NT Port-List Number-#*

Where,

NT Port is from 1 to 2.

List Number is from 01 to 16.

By default, Number List = 06 is assigned to the NT Port.

Example:

122-03-#* (Clear all location of number list 03)

- 122-05-#*** (Clear all location of number list 05)
- 121-03-01-95-#*** (Program 95 at index 1 of No. 03, dialed No. list)
- 121-05-01-91-#*** (Program 91 at index 1 of No. list 05, substitute number list)
- 622-1-03-#*** (Assign dial number list to mobile port1)
- 623-1-05-#*** (Assign substitute number list to mobile port 1)

Important Point:

- User can use ANT for dialing international number also. For this '+' sign has to be programmed in the substitute number list. It can be done by entering '#8' from the telephone keypad. For example, +91266 can be entered by string #891266.

Relevant Topic:

1. Number Lists 113

=X=X=

Call Detail Recording (CDR)

What's this?

The SIMADO GBR42, supports a facility to store the details of calls made through it. This is called Call Detail Recording (CDR).

- Maximum 200 records can be stored in the buffer.
- The system offers facility to store the call details and even to get the report on the COM port as per the requirement.

How it works?

- A call is stored when the call gets over.
- When SE restarts the 'Simado GBR42', process of printing the CDR Report will be stopped (even if started before). SE will have to start the CDR Printing process again if required.

CDR Format:

Each CDR report has specific parameters or field with fixed column position. Details of date and page number are also given as shown in the report at the end of chapter.

Each record has following parameters or fields:

- Serial Number.
- Originating Port (O-PORT) (NT, TE, Mobile).
- Terminating Port (D-PORT) (NT, TE, Mobile).
- Called Party Number (Maximum 16 digits).
- Calling Party Number (Maximum 16 digits).
- Date (DD-MM-YYYY).
- Time (HH:MM:SS).
- Duration (four digits).

Filter Command:

Various filters can be used to generate a report. These commands enable the user to select the type of call reports generated. It is possible to program the following filters.

Default values for the filter commands are as given below in brackets:

Description	Command (default)
Start or Stop the printing of CDR report	171-Code-#* (1)
Enable/Disable filter set for the calls terminated on TE port	172-Code-#* (1)
Printing of all calls terminated on TE ports	173-TE Port-TE Port-#*
Disable printing of all calls terminated on TE ports	173-#*
Enable/Disable filter set for the calls terminated on NT port	174-Code-#* (1)
Printing of all calls terminated on NT ports	175-NT Port-NT Port-#*
Disable printing of all calls terminated on NT ports	175-#*
Enable/Disable filter set for the calls terminated on Mobile port	176-Code-#* (1)
Printing of all calls terminated on Mobile ports	177-Mobile Port-Mobile Port-#*
Disable printing of all calls terminated on Mobile ports	177-#*
Enable/Disable filter set for the calls originated on TE port	178-Code-#* (1)
Printing of all calls originated on TE ports	179-TE Port-TE Port-#*
Disable printing of all calls originated on TE ports	179-#*
Enable/Disable filter set for the calls originated on NT port	180-Code-#* (1)
Printing of all calls originated on NT ports	181-NT Port-NT Port-#*
Disable printing of all calls originated on NT ports	181-#*
Enable/Disable filter set for the calls originated on Mobile port	182-Code-#* (1)

Printing of all calls originated on Mobile ports	183-Mobile Port-Mobile Port-#*
Disable printing of all calls originated on Mobile ports	183-#*
To set filter to print all calls from-to Date	184-DD-MM-YYYY-DD-MM-YYYY-#*(01-01-06 to actual or current date)
To set filter to print all calls within a given time range	185-HH-MM-HH-MM-#* (0000 to 2359)
To set filter to print all calls with Called Party Number matching the Number list	186-Called Party Number List-#* (01)
To set filter to print all calls with Calling Party Number matching the Number list	187- Calling Party Number List-#* (01)
To set filter to print all calls with call duration more than specified	188-Seconds-#* (0001)
To Default all CDR Filter	189-#*
Clear the CDR buffer	190-Reverse SE Password-#* (4321)

Where,

Mobile Port is from 1 to 4.

TE Port is from 1 to 2.

NE Port is from 1 to 2.

Code	Meaning	Start/Stop
0	Disable	Abort Report
1	Enable	Start Report

Seconds is from 0001 to 9999.

Example:

A call originates on a NT port having routing type 'Fixed Type' and TE in the selected by the user then call gets stored in CDR on given below:

- S-Port : NT Port.
- Calling Party Number : Blank.
- Destination port : TE Port.
- Called Party Number : Number dialed by the NT

Matrix

In above mentioned case, if 'Fixed Dialing' is enabled on TE Port, call originated from mobile port then the call gets stored in CDR as mentioned below:

- S-Port : Mobile Port.
- Calling Party Number : Received from the GSM Network.
- Destination port : TE Port.
- Called Party Number : Fixed Destination Number, programmed for the Mobile Port.

For taking report of all the calls, originated from mobile port 1 to mobile port 3, following commands can be used:

183-1-3-#* (To assign Mobile Port number from and to)

171-1-#* (To start report)

Important Point:

- Filter for calling party number list and called party number list will always be applicable and record will contain, numbers programmed or blank, if no number is programmed.

Relevant Topic:

1. Communication Port 65

```
CALL DETAIL RECORDS REPORT as on 06-Dec-2007 at 15:56:51
```

Source Port	Destination Port	Num List: Called - 01 Calling - 01	
NT : 1 To 2	NT : 1 To 2	Date: 01-Jan-2006 To 06-Dec-2007	
TE : 1 To 2	TE : 1 To 2	Time: 00:00:00 To 23:59:00	
MOB: 1 To 4	MOB: 1 To 4	Dur(sec): 0001	

Sr.	SPort	DPort	Called Number	Calling Number	Date	Time	Dur
1	TE	1 MOB	1 9898906335	3263010123456789	01-Jan-2006	00:34:35	14
2	TE	1 MOB	1 9898906335	3263010123456789	01-Jan-2006	00:34:58	12
3	TE	1 NT	1		01-Jan-2006	19:14:48	4
4	TE	1 NT	1		01-Jan-2006	19:15:09	8
5	TE	1 NT	1		01-Jan-2006	19:15:25	10
6	TE	1 NT	1		01-Jan-2006	19:15:49	9
7	TE	1 NT	1		01-Jan-2006	19:16:05	11
8	NT	1 TE	1 3201919898507327		01-Jan-2006	19:16:38	17
9	NT	1 TE	1 3201919898507331		01-Jan-2006	19:17:16	14
10	NT	1 TE	1 3201919825816195		01-Jan-2006	19:17:42	12
11	NT	1 TE	1 11111		01-Jan-2006	19:18:05	17
12	TE	1 NT	1		01-Jan-2006	19:18:31	3
13	NT	1 TE	1 3002		01-Jan-2006	19:18:46	23
14	NT	1 TE	1 3555		01-Jan-2006	19:19:20	8
15	NT	1 TE	1 3201919898089490		01-Jan-2006	19:19:40	65
16	NT	1 TE	1 3003		01-Jan-2006	19:20:56	203

Matrix SIMADO GBR42 VIR5 Page 01

=X=X=

Call Duration Control (CDC)

What's this?

- Matrix GBR42 supports control of Call Duration for each call.
- User can program the period upto which call should be continued.
- Due to this feature, any port will get disconnected if it is left accidentally open.

How it works?

- The CDC timer is a system feature. The CDC timer is programmable with range 01 to 99 minutes. The timer should be programmed keeping in mind the users involved in the conversation.
- After expiry of the CDC timer, both ports involved in the conversation get released.

How to program?

Step 1: To enable/disable CDC using command **191**.

Step 2: To program the CDC timer using command **192**.

Step 1

Use following command to enable/disable CDC:

191-Code-#*

Where,

Code	Meaning
0	Disable
1	Enable

By default, CDC is enabled.

Step 2

Use following command to program the CDC timer:

192-CDC Timer-#*

Where,

CDC Timer is from 01 to 99 minutes.

By default, CDC Timer is 99 minutes.

Example:

A person is frequently talking from ISDN line for more then 10 minutes. Then to restrict the talk, program CDC feature by using

following commands.

191-1-#* (Enable CDC, if it is disabled)

192-03-#* (Program CDC timer for 3 minutes)

Relevant Topic:

1. Allowed and Denied Lists 33

=X=X=

Call Proceeding Tone

What's this?

- Some sort of signaling tone is required when a call is terminated on Mobile/TE/NT Port to inform the user that call is established. It is done with special Call Proceeding Tone and can be generated by network or gateway.
- SIMADO GBR42 supports facility of playing feature tone locally to the caller in case of destination network doesn't give any audible indication for the progress of call.
- Call Proceeding Tone flag programmed on destination port determines the feature tone to be played by the SIMADO GBR42 or of the network.

How it Works?

- Call Proceeding Tone flag is of relevance only, if source port is BRI-NT or DID is enabled on BRI-TE/Mobile port.

For Mobile Port

- When the call is terminated on (routed to) the mobile port, the originating port can be connected to a tone generator (feature tone) or to the GSM network.
- If the originating port is connected to the GSM network, immediately on end of dialing, the caller can listen to the tone received from the GSM network.
- Whereas if the caller is connected to the feature tone generator, the caller gets feature tone (which nearly simulates call routing tone of the network) till 'Call Progress Message' is received from the GSM network.
- On receipt of first Call Progress Message, the originating port is connected to the terminating port.

For TE Port

- When the call is terminated on (routed to) the TE port, the originating port can be connected to a tone generator (feature tone) or to the ISDN network.
- If the originating port is connected to the ISDN network immediately on end of dialing, the caller can listen to the tone received from the ISDN network.

- Whereas, if the caller is connected to the feature tone generator, the caller gets feature tone (which nearly simulates call routing tone of the ISDN network) till further call progress message is received from the ISDN network.

For NT Port

- When NT is terminating port the call progress tones generated by SIMADO GBR42 shall be played as per state of the call.

How to program?

Step 1: To set call proceeding tone for mobile port using command **307**.

Step 2: To programming type of call proceeding tone on TE port using command **408**.

Step 1

Use following command to set call proceeding tone for mobile port:

307-Mobile Port-Code-#*

Where,

Mobile Port is from 1 to 4.

Code	Meaning
1	SIMADO Tone
2	GSM Network Tones

By default, Call Proceeding Tone is '2'.

Step 2

Use following command to program type of call proceeding tone on TE port:

408-TE Port-Code-#*

Where,

TE Port is from 1 to 2.

Code	Meaning
1	SIMADO Tone
2	ISDN Network Tone

By default, Call Proceeding Tone Type is 2.

Important Point:

- If the synchronization with the ISDN or GSM network is lost while making a call then originating port will get 'Error Tone'.

Relevant Topics:

1. Mobile Port Parameters 96
2. TE Port Parameters 146

=X=X=

Call Processing in SIMADO GBR42

What's this?

- This chapter includes for detailed explanation of call routing from source port to the destination port. Calls on each port are placed depending upon the various routing type, member selection method etc.
- The following block diagram shows the flow of Call Processing in the SIMADO GBR42:

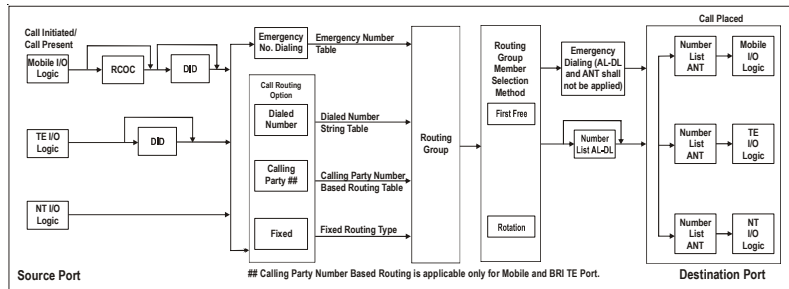

Explanation of DID

- DID is Direct Inward Dialing. It is the feature by which the caller can access the system and dial the required number or enter programming mode on getting the feature tone. The extension number should be dialed before expiry of the tone. Otherwise caller will get 'Error Tone'.

How it works?

The call routing is explained for following three cases:

- Calls originating from Mobile Port.
- Calls originating from TE Port.
- Calls originating from NT Port.

Originating Port : Mobile

- If the source port is **Mobile Port** and **RCOC** feature is enabled the call is routed as per RCOC logic. If calling party number is matching as per the RCOC table then the call is routed to the port that originated the call. If the feature RCOC is disabled or number match is not found, the call is routed as per DID (Direct Inward Dialing) logic.

- If **DID** is enabled user gets the feature tone of the system and dials the number during this tone. But if number is not dialed during this period, or DID is disabled then the **Fixed Destination** number is dialed after expiry of First Digit Wait Timer if Fixed Dialing is enabled or call is terminated if Fixed Dialing is not enabled.
- If destination number is dialed during Feature Tone of the system, the Number is checked for **Emergency Number Table**. If match is found the Emergency Call is routed as per Routing Group for the Emergency Number. If the Routing Group is not available, user will get 'Error Tone'.
- If the dialed number does not match to the Emergency Number table, then call is routed as per Routing Option for the current time zone. Refer chapter '**Routing Type**' for more details.
- The destination port is selected as per the member Selection method on the selected Routing Group.
- The number is checked first for **Allowed-Denied list** assigned to the source port. If it is valid, then **Alternate Number Translation** logic is applied and the number is dialed.
- If the number is not valid as per Allowed-Denied list, then user will get 'Error Tone' and call is disconnected.
- Similarly call routing for this and for the 'Source Port' as TE or NT is explained by flowchart on next page.

The flowchart explains following main stages of call routing:

- Call Routing when the source port is Mobile or TE or NT.
- RCOC enabled/disabled and dialed number matches with RCOC table.
- DID is enabled/disabled.
- Fixed Dialing enabled/disabled.
- Dialed number matches with Emergency Number table.
- Routing Type as per the time zone.

Relevant Topics:

1. Allowed and Denied Lists 33
2. Returned Calls to Original Callers 119
3. Calling Party Number Based Routing 59
4. Routing Group 124
5. Routing Type 131

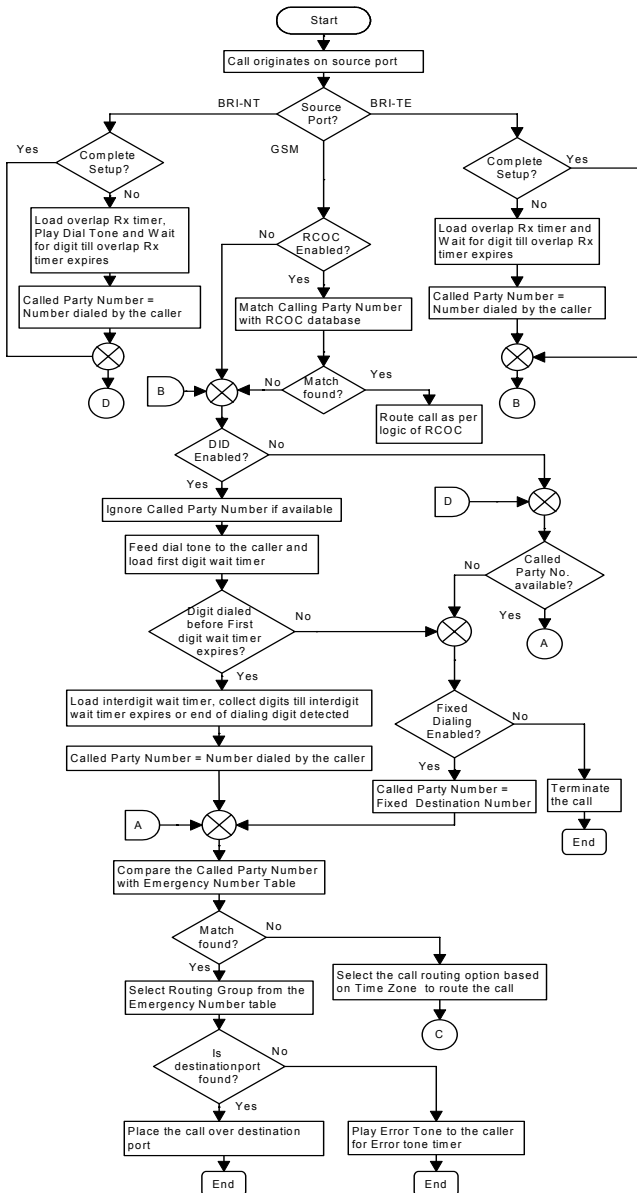

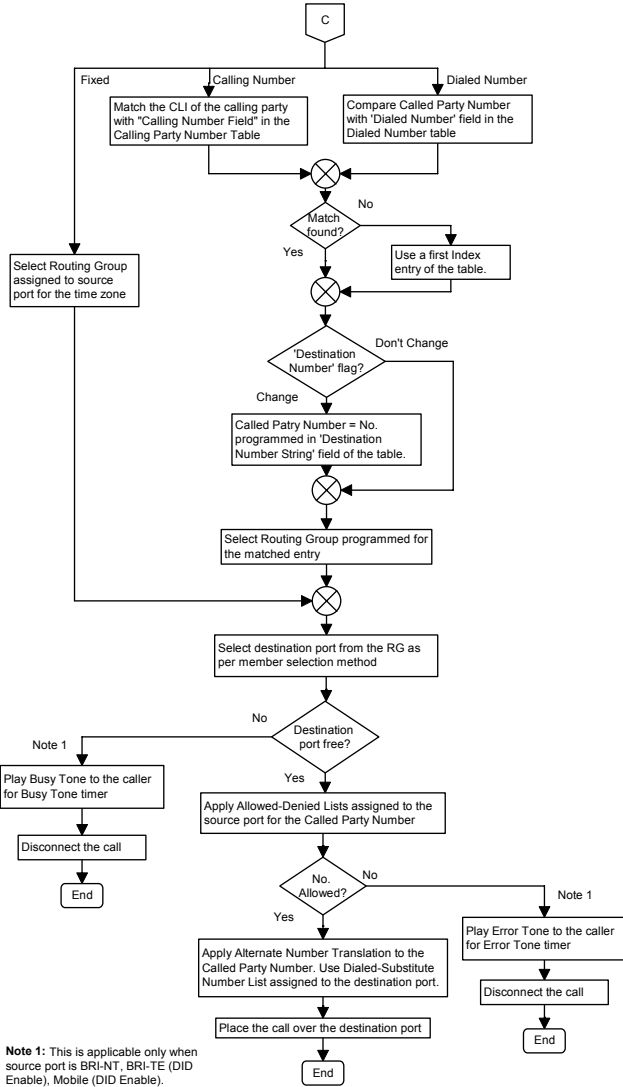

=X=X=

Call Progress Tones

What's this?

The SIMADO GBR42 supports different types of tones to indicate the response for various events while establishing a call. These tones are called Call Progress Tones. The tones are generated in response to dialing of codes and commands. Various country and region have the specific standard of types of tones. Based on this, thirty two countries are supported for call progress tones by the system. Depending on the combination of frequency and cadence, the system provides following tones:

- Dial Tone.
- Confirmation Tone.
- Ring Back Tone.
- Error Tone.
- Busy Tone.
- Gateway Tone (Feature Tone).

Dial Tone

This tone is played on BRI-NT port.

- Dial Tone stays for time of First Digit Wait Timer 10 seconds for the port.

Confirmation Tone

This tone is given as continuous, fast beeps to indicate that the system has successfully executed a feature command/programming command issued by the user. This is also called the Programming Confirmation Tone.

- Confirmation Tone stays for 5 seconds.

Ring Back Tone

When the system receives a call and the telephone connected to BRI-NT port is ON-Hook, then the telephone starts ringing and the caller gets Ring Back Tone.

Error Tone

This is given when the user performs some invalid operation or some denied access.

- Error Tone stays for 5 seconds.

Busy Tone

When a call is made by system and it gets response for busy, Caller gets busy tone.

- Busy Tone stays for 5 seconds.

Gateway Tone (Feature Tone)

Refer chapter 'Call Proceeding Tone' for more details.

How to program?

Use the following command to select the country for CPTG:

213-Code-#*

Where,

Code	Country	Dial Tone		Ring Back Tone		Busy Tone		Error Tone		Confirmation Tone		Feature Tone			
		Cadence		Cadence		Cadence		Cadence		Cadence		Cadence			
		Freq.	Hz	Freq.	Hz	Freq.	Hz	Freq.	Hz	Freq.	Hz	Freq.	Hz		
01	Australia	425*25	cont.	400*25	cont.	400*25	0.4on 0.2off 0.4on 2.0off	425	0.375on 0.375off	425	0.375on 0.375off	400	0.1on 0.1off	400	0.1on 0.9off
02	Argentina	425	cont.	425	cont.	425	1.0on 4.0 off	425	0.3on 0.2off	425	0.3on 0.4off	400	0.1on 0.1off	400	0.1on 0.9off
03	Belgium	425	cont.	425	cont.	425	1.0on 3.0off	425	0.5on 0.5off	425	0.167on 0.167off	400	0.1on 0.1off	400	0.1on 0.9off
04	Brazil	425	cont.	425	cont.	425	1.0on 4.0 off	425	0.25on 0.25off	425	0.25on 0.25 off	400	0.1on 0.1off	400	0.1on 0.9off
05	China	450	cont.	450	cont.	450	1.0on 4.0off	450	0.35 on 0.36off	450	0.7on 0.7off	400	0.1on 0.1off	400	0.1on 0.9off
06	Egypt	425*50	cont.	425*50	cont.	425*50	2.0on 1.0off	425*50	1.0on 4.0off	450	0.5on 0.5off	400	0.1on 0.1off	400	0.1on 0.9off
07	France	440	cont.	440	cont.	440	1.5on 3.5off	440	0.5on 0.5off	440	0.25on 0.25off	400	0.1on 0.1off	400	0.1on 0.9off
08	Germany	425	cont.	425	cont.	425	1.0on 4.0off	425	0.48on 0.48off	425	0.24on 0.24off	400	0.1on 0.1off	400	0.1on 0.9off
09	Greece	425	0.2on 0.3off 0.7on 0.8off	425	1.0on 4.0off	425	1.0on 4.0off	425	0.3on 0.3off	425	0.15on 0.15off	400	0.1on 0.1off	400	0.1on 0.9off
10	India	400*25	cont.	400*25	cont.	400*25	0.4on 0.2off 0.4on 2.0off	400	0.75on 0.75off	400	0.25on 0.25off	400	0.1on 0.1off	400	0.1on 0.9off
11	Indonesia	425	cont.	425	cont.	425	1.0on 4.0off	425	0.5on 0.5off	425	0.25on 0.25off	400	0.1on 0.1off	400	0.1on 0.9off
12	Iran	425	cont.	425	cont.	425	1.0on 4.0off	425	0.5on 0.5off	425	0.25on 0.25off	400	0.1on 0.1off	400	0.1on 0.9off
13	Israel	400	cont.	400	cont.	400	1.0on 3.0off	400	0.5on 0.5off	400	0.25on 0.25off	400	0.1on 0.1off	400	0.1on 0.9off
14	Italy	425	cont.	425	cont.	425	1.0on 4.0off	425	0.5on 0.5off	425	0.2on 0.2off	400	0.1on 0.1off	400	0.1on 0.9off
15	Japan	400	cont.	400*20	cont.	400	1.0on 2.0off	400	0.5on 0.5off	400	0.25on 0.25off	400	0.1on 0.1off	400	0.1on 0.9off
16	Kenya	425	cont.	425	cont.	425	0.67on 3.0off 1.5on 5.0off	425	0.2on 0.6off 0.2on 0.6off	425	0.2on 0.6off	400	0.1on 0.1off	400	0.1on 0.9off
17	Korea	350+440	cont.	440+480	cont.	440+480	1.0on 2.0off	480+620	0.5on 0.5off	480+620	0.3on 0.2off	400	0.1on 0.1off	400	0.1on 0.9off
18	Malaysia	425	cont.	425	cont.	425	0.4on 0.2off 0.4on 2.0off	425	0.5on 0.5off	425	0.5on 0.25off	400	0.1on 0.1off	400	0.1on 0.9off
19	Mexico	425	cont.	425	cont.	425	1.0on 4.0off	425	0.25on 0.25off	425	0.25on 0.25off	400	0.1on 0.1off	400	0.1on 0.9off
20	New Zealand	400	cont.	400+450	cont.	400	1.0on 2.0off 0.4on 2.0off	400	0.5on 0.5off	400	0.25on 0.25off	400	0.1on 0.1off	400	0.1on 0.9off
21	Philippines	425	cont.	425+480	cont.	425+480	1.0on 4.0off	480+620	0.5on 0.5off	480+620	0.25on 0.25off	400	0.1on 0.1off	400	0.1on 0.9off
22	Poland	425	cont.	425	cont.	425	1.0on 4.0off	425	0.5on 0.5off	425	0.5on 0.5off	400	0.1on 0.1off	400	0.1on 0.9off
23	Portugal	425	cont.	425	cont.	425	1.0on 5.0off	425	0.5on 0.5off	450	0.33on 1.0off	400	0.1on 0.1off	400	0.1on 0.9off
24	Russia	425	cont.	425	cont.	425	0.8on 3.2off	425	0.4on 0.4off	425	0.25on 0.25off	400	0.1on 0.1off	400	0.1on 0.9off
25	Saudi Arabia	425	cont.	425	cont.	425	0.4on 0.2off 0.4on 2.0off	425	0.5on 0.5off	425	0.25on 0.25off	400	0.1on 0.1off	400	0.1on 0.9off
26	Singapore	425	cont.	425*24	cont.	425*24	0.4on 0.2off 0.4on 2.0off	425	0.75on 0.75off	425	0.25on 0.25off	400	0.1on 0.1off	400	0.1on 0.9off
27	South Africa	400*33	cont.	400*33	cont.	400	0.4on 0.2off 0.4on 2.0off	400	0.5on 0.5off	400	0.25on 0.25off	400	0.1on 0.1off	400	0.1on 0.9off
28	Spain	425	cont.	425	cont.	425	1.5on 3.0off	425	0.2on 0.2off	425	0.25on 0.25off	400	0.1on 0.1off	400	0.1on 0.9off
29	Thailand	400*50	cont.	400	cont.	400	1.0on 4.0off	400	0.5on 0.5off	400	0.3on 0.3off	400	0.1on 0.1off	400	0.1on 0.9off
30	Turkey	450	cont.	450	cont.	450	2.0on 4.0off	450	0.5on 0.5off	450	0.2on 0.2off 0.6on 0.2off	400	0.1on 0.1off	400	0.1on 0.9off
31	UAE	350+440	cont.	400+450	cont.	400	0.4on 0.2off 0.4on 2.0off	400	0.375on 0.375off	400	0.4on 0.35off 0.225on 0.525off	400	0.1on 0.1off	400	0.1on 0.9off
32	UK	350+440	cont.	400+450	cont.	400	0.4on 0.2off 0.4on 2.0off	400	0.375on 0.375off	400	0.4on 0.35off 0.225on 0.525off	400	0.1on 0.1off	400	0.1on 0.9off
33	USA/Canada	350+440	cont.	440+480	cont.	440+480	2.0on 4.0off	480+620	0.5on 0.5off	480+620	0.25on 0.25off	400	0.1on 0.1off	400	0.1on 0.9off

By default, Country is 10 (India).

Remarks:

- f1*f2 : 'f1' is modulated by 'f2'.
- f1+f2 : Two frequencies without modulation.

Relevant Topic:

1. Call Proceeding Tone 56

=X=X=

Calling Party Number Based Routing

What's this?

- SIMADO GBR42 provides a facility to route incoming calls based on CLI number, to particular stations of the programmed Routing Group. This is known as CLI Based Routing or Calling Party Number Based Routing.
- If required, user can program the number string using following Codes for the Special digits:

Special Digit	Code
Flash	#2
Pause	#3
A	#4
B	#5
C	#6
D	#7
+	#8
#	##

How it works?

- CLI based routing is based on CLI routing table, which can be programmed for maximum 200 entries.
- The calling party number received from the call originating port is compared with the numbers in the CLI routing table and if the match is found, the number is routed as per the table else the call is routed as per the 'changed called number flag' for that table index number. For call routing, the port will be selected as per the routing group programmed. The CLI routing table looks as shown below:

Index	Calling Number	Routing Group	Change Called Number?	New Called Number
001	Note ¹	01	Yes	Blank
:	:	:	:	:
:	:	:	:	:
200	Blank	01	Yes	Blank

Note¹: The first row of the Table contains routing parameters used when No match is found with Calling Numbers programmed in the table and is not programmable.

- CLI based routing option is not applicable for NT port.
- But CLI based routing option can be used for Mobile and TE port.

How to program?

Step 1: To program the CLI Number String using the command **131**.

Step 2: To program the Routing Group for a CLI number using the command **132**.

Step 3: To program the Change Called Number flag using the command **133**.

Step 4: To program the new called number at an index in the CLI routing table using the command **134**.

Step 5: To clear entire CLI Based routing Table using command **135**.

Step 1

Use following command to program the CLI number string:

131-CLI Routing Table Index-CLI Number String-#*

Where,

CLI Routing Table Index is from 002 to 200. Index 001 is reserved for default parameters for the case of routing if CLI is not matching.

CLI Number String is of maximum 16 digits. Number string ranges from 0-9, #, * and +.

By default, CLI Number String is Blank.

Use following command to clear number string at an index in the CLI routing table:

131-CLI Routing Index-#*

Step 2

Use following command to program the routing group for a CLI number:

132-CLI Routing Table Index-Routing Group-#*

Where,

CLI Table Routing Index is from 001 to 200. In this case, Routing Group at Index 001 will specify which routing group is to be used when CLI does not match with CLI table.

Routing Group is from 01 to 16.

By default, Routing Group is 01.

Step 3

Use following command to program the change called number flag:

133-CLI Routing Index-Code-#*

Where,

CLI Routing Index is from 002 to 200.

Code	Meaning
0	Do not change called number
1	Change called number

By default, Change Called Number Flag is 1.

- If Code is 0 then call will be routed with the destination number dialed by the caller or the fixed destination number programmed. If fixed destination number is not programmed, then the destination number dialed by the system will be 'Blank'.
- If code is 1 then call will be routed with the destination programmed in the calling party number routing table entry.

Step 4

Use following command to program the new called number at an index in the CLI routing table:

134-CLI Routing Table Index-New Called Number-#*

Where,

CLI Routing Table Index is from 001 to 200.

New Called Number is of 16 digits. Number string ranges from 0-9, # and *.

By default, New Called Number is Blank.

Use following command to clear the new called number at an index in the CLI routing table:

134-CLI Routing Table Index-#*

Where,

CLI Routing Index is from 001 to 200.

Step 5

Use following command to clear entire CLI Based Routing Table:

135-#*

Example:

A user expect all his incoming calls from 9898074305 should land on his station connected extension XX as per routing group, at NT1 port and all calls from 9426054720, should land on the destination number=YY. Program for this as shown below:

131-002-9898074305-#* (Program CLI)

131-003-9426054720-#* (Program CLI)

132-002-01-#* (Program routing group 01 for index 001, which has NT1 as member)

133-003-1-#* (Replace destination number)

134-003-YY-#* (Program destination number)

Relevant Topic:

1. Routing Group 124

=X=X=

Clock Synchronization

What's this?

This chapter gives brief idea about system clock derivation. When data is transmitted from the system to external lines or system receives data from the external lines, it is required that the transmitter and receiver are properly synchronized. Otherwise intermittent, clock slips can occur. A clock slip can generate a loss or addition of data to the data stream.

- There are three ways of Clock Synchronization:
 - Using the Data Clock.
 - Using the External Clock (Clock is sent by the network on a dedicated cable pair).
 - Using the Internal Clock.
- The system does not support External Clock.
- For the SIMADO GBR42, fixed hierarchy of clock sources is Internal, TE1 and TE2.

How it works?

- Matrix GBR42 does not support external clock.
- User should configure the gateway such that when it is connected to the PSTN, it will extract the clock from the incoming data whereas, if it is used to form a private network then it will use Internal Clock.
- There are 3 clock sources for the SIMADO GBR42 which are programmable.
- If any one port is synchronized, the SIMADO GBR42 shall select it as clock master.
- If none of the port is synchronized out of this table, it shall give priority to internal clock.

How to program?

Use following command to assign Priority to select the clock source for the SIMADO GBR42:

215-Priority-Clock Source-#*

Where,

Priority is from 1 to 3, 1 is highest priority and 3 Least priority.

Priority	Meaning
1	Internal
2	TE-1
3	TE-2

Clock Source	Meaning
1	Internal
2	TE-1
3	TE-2

By default, following priorities are given for the clock synchronization: Internal or TE-1 Or TE-2.

=X=X=

Communication Port

What's this?

- The SIMADO GBR42 supports a communication port which is used for following purpose:
 - To send the Call Detail Recording (CDR) report to the computer.
 - For programming through Jeeves.
 - To send system event log to the PC.
- Based on application, a process is assigned to the COM port.

How to use it?

- Connect the communication port of the gateway with the communication port of the computer using a crossed communication cable. Matrix provides a crossed communication cable with 9-pin D-type female connector on both the sides.

The Jeeves software for the gateway can be installed on any standard computer with Window and NT operating system.

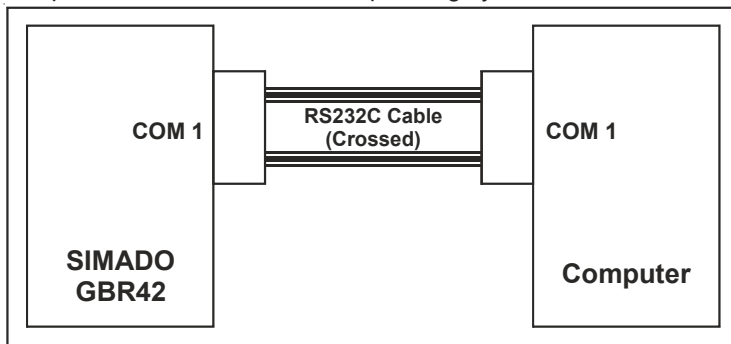

Following attributes are used for the system and are not programmable:

Baud Rate	19200bps
Stop Bit	1
Parity	Mark
Data Bits	8
Flow Control	None

Following table gives the pin out details of the COM port:

Pin No.	Signal Name
1	Data Carrier Detect (DTD)
2	Receive Data (RXD)
3	Transmit Data (TXD)
4	Data Terminal Ready (DTR)
5	Ground (GND)
6	Data Set Ready (DSR)
7	Request to Send (RTS)
8	Clear to Send (CTS)
9	Ring Indicator (IR)

How to program?

Use following command to enable/disable event logging process:

214-Code-#*

Where,

Code	Meaning
0	Disable
1	Enable

By default, Event Logging Process is 0.

Important Points:

- Only one process can be started from COM port: Jeeves, CDR report or Debugging.
- From Jeeves, report = start/stop or debug = start/stop can be operated.

Relevant Topics:

1. Call Detail Recording (CDR) 43
2. Jeeves 94
3. Programming the System 115

=X=X=

Daylight Saving Time Adjustment

What's this?

- It is the new local time a region is assigned for a portion of the year, usually an hour forward from its standard official time.
- The clocks are advanced at the beginning of the daylight saving time and delayed at the end of the daylight saving time. For this, SIMADO GBR42 supports a feature 'Daylight Savings Time Adjustment'.

How it works?

- DST Adjustment type can be set from the options: None, Day-Month wise or Date-Month wise. It will be programmed for both DST Forward Time and DST Backward Time for the country.
- The option 'None' is selected, if the country does not support DST. For India, the option will be 'None'.
- The option 'Day-Month wise' is selected; if the DST is effective on the programmed Ordinal number day of the month every year for a country. 'Ordinal number' can be set from '1' to '5'. For example, it will be set to '1' for the DST of first Sunday of the month and to '3' for the third Sunday of the month.
- The option 'Date-month wise' is selected, if the DST is effective on the programmed date of the month every year for a country.

How to program?

Step 1: To select DST Forward Time Adjustment Type using command **111**.

Step 2: To set time for DST Forward Type 'Day-Month wise' option using command **112**.

Step 3: To set time for DST Forward type 'Date-Month wise' option using command **113**.

Step 4: To select DST Backward Time Adjustment Type using command **114**.

Step 5: To set time for DST Backward Type 'Day-Month wise' option using command **115**.

Step 6: To set time for DST Backward type 'Date-Month wise' option using command **116**.

Step 1

Use following command to select DST Forward Time Adjustment Type:

111-DST Forward Time Adjustment-#*

Where,

DST Forward Time Adjustment	Meaning
0	None
1	Day-Month wise
2	Date-Month wise

By default, DST Forward Time Adjustment Type is 0.

Step 2

Use following command to program DST Forward parameters for 'Day-Month wise' option:

112-Ordinal Number-Day-Month-Hour-Minute-Hour-Minute-#*

Where,

Ordinal Number is from 1 to 5. (1= First, 2=Second, 3=Third, 4=Fourth and 5=Fifth).

Day is from 1 to 7 (Sunday is Day1 and Saturday is Day7)

Month is from 01 to 12.

Hour is from 00 to 23.

Minute is from 00 to 59.

First Hour-Minute is for current settings whereas the Second Hour-Minute is for time to which the clock should be forwarded to.

By default, Ordinal Number is 1, Day is 1, Month is 01, Hour is 00 and Minute is 00.

For e.g. In New Zealand, the DST starts on Last Sunday of October.

The clock changes from 02:00 to 03:00.

Following programming should be done to affect DST in New Zealand.

112-5-1-10-02-00-03-00-#*

Note:

For last Sunday (or other day) of the month, always set Ordinal Number = 5. For e.g. If the month has 4 Sundays in a particular Calendar year then the last Sunday would be automatically the fourth one and if the month has 5 Sundays in a particular month of the Calendar year then the last Sunday would be automatically the fifth

one, and while programming it shall not be known that in a given year, the last Sunday would be fourth or fifth one. Hence program the Ordinal Number = 5 for such cases.

Step 3

Use following command to program DST Forward parameters for 'Date-Month wise' option:

113-Date-Month-Hour-Minute-Hour-Minute-#*

Where,

Date is from 01 to 31, Month is from 01 to 12, Hour is from 00 to 23,

Minute is from 00 to 59.

By default, Date is 01, Month is 01, Hour is 00 and Minute is 00.

For e.g. In Cuba, the DST starts on 1st April of every year. The clock changes from 01:00 to 02:00. Following command should be issued by the SE to affect DST.

113-01-04-01-00-02-00-#*

For e.g. In Syria, the DST starts on 1st April of every year. The clock changes from 00:00 to 01:00. Following command should be issued by the SE to affect DST.

113-01-04-00-00-01-00-#*

Step 4

Use following command to select DST Backward Time Adjustment

Type:

114-DST Backward Time Adjustment Type-#*

Where,

DST Backward Time Adjustment Type	Meaning
0	None
1	Day-Month wise
2	Date-Month wise

By default, DST Backward Time Adjustment Type is 0.

Step 5

Use following command to program DST Backward parameters for 'Day-Month wise' option:

115-Ordinal Number-Day-Month-Hour-Minute-Hour-Minute-#*

Where,

Matrix

Ordinal Number is from 1 to 5. (1=First, 2=Second, 3=Third, 4=Fourth and 5=Fifth), Refer Note for the command '112'.

Day is from 1 to 7 (Sunday is Day1 and Saturday is Day7)

Month is from 01 to 12

Hour is from 00 to 23

Minute is from 00 to 59

First Hour-Minute is for current settings whereas the Second Hour-Minute is for time to which the clock should be backwarded to.

For e.g. In New Zealand, the DST ends on Third Sunday of March. The clock changes from 03:00 to 02:00. Following command should be issued to affect DST in New Zealand.

115-3-1-03-03-00-02-00-#*

For e.g. In Cuba, the DST ends on last Sunday of October every year. The clock changes from 23:59 (in fact 00:00 midnight) to 23:00. Following command should be issued by the SE to affect DST.

115-5-1-10-23-59-22-59-#*

Step 6

Use following command to program DST Backward parameters for 'Date-Month wise' option:

116-Date-Month-Hour-Minute-Hour-Minute-#*

Where,

Date is from 01 to 31, Month is from 01 to 12, Hour is from 00 to 23,

Minute is from 00 to 59.

By default, Date is 01, Month is 01, Hour is 00 and Minute is 00.

For e.g. In Syria, the DST ends on 1st October of every year. The clock changes from 23:59 (00:00 midnight of 1st October) to 23:00. This means that DST should be changed on 30th Sept. at 23:59 to 23:00.

Following command should be issued by the SE to effect DST.

116-30-09-23-59-22-59-#*

Important Points:

- Note that the day does not get changed by the system automatically while forwarding the clock or reverting back to normal. Hence the SE has to enter the current time and the forward

backward time keeping this aspect in mind.

- For e.g. In Chile, DST is advanced on Second Saturday of October from 00:00 to 01:00. This means that on Second Saturday of October at 00:00, the clock should be advanced to 01:00. To effect this in the system, the SE should use following command:
112-2-7-10-0000-0100-#*
- For e.g. In Chile, DST is reverted back to normal on Second Sunday of March at 00:00 to Second Saturday of March 23:00. To effect this, SE should use following command:
115-2-7-03-23:59-22:59-#*

Relevant Topics:

1. Real Time Clock (RTC) 116
2. Time Table 159

=X=X=

Default the Configuration

What's this?

- Every system comes with pre-defined set of variables like number list, timers and other parameters. These pre-defined settings are called default settings.
- The default value of each programmable parameter is mentioned in the respective section. If the default setting suits your requirement then, you may not even require programming the system and the system will work with the default settings.

When to use it?

Many times it happens that due to some programming error, the system goes haywire and you are unable to analyze the problem. During such a situation, it is advisable to default the system. However, software default of the system can be done from the programming mode and hence programming password should be known. If you forget the password default cannot be done and in that case hardware default of the system should be done. For this, refer chapter '[Configuring the System](#)'.

How to program?

Use the following command to assign default configuration to the system:

201-Reverse SE Password-#*

Where,

SE Password is of 4 digits ranging from 0000 to 9999.

By default, SE Password is 1234.

The following are the parameters, which will not default when the system is default:

- CDR Buffer
- Real time Clock (RTC)
- Call Progress Tone Generation Type
- Mobile SIM PIN

Relevant Topics:

1. [Getting Started](#) 24
2. [Programming the System](#) 115

=X=X=

Dialed Number Based Routing

What's this?

SIMADO GBR42, has the facility to initiate the call from a specific port based on the number string dialed. This is called Dialed Number Based Routing. For this, a separate routing group is assigned for a specific number string and the Member of the group will be the ports for dialing the Number.

How it works?

- The routing group to be used for placing the call is determined from the number dialed.
- This logic is used when routing type is programmed as dialed number based.
- The dialed number string is compared with the “Dialed Number String Table” and if match is found then the call is routed on the routing group assigned to that number string.
- If matching entry is not found in the dialed number string table then the call is routed as per routing group of first index of table.
- This routing group can be formed such that number can be dialed out from the port, for which call cost will be minimum. Different prefix can be programmed for the required numbers to be dialed out from the port which will cost minimum compared to other ports in the routing group assigned to that prefix number string.
- Thus Least Cost Routing (LCR) can be implemented by suitable programming of the table.
- The dialed number string table contains maximum 500 entries.
- If required, user can program the number string using following Codes for the Special digits:

Special Digit	Code
Flash	#2
Pause	#3
A	#4
B	#5
C	#6
D	#7
+	#8
#	##

How to program?

Step 1: To program the prefix string in the dialed number string table using command **151**.

Step 2: To program the routing group in the dialed number string table using command **152**.

Step 3: To program the “Change Called Number?” flag at an index into the dialed number based routing table using command **153**.

Step 4: To program new called number at an index in the dialed number table using command **154**.

Step 5: To clear the entire dialed number string table using command **155**.

Step 1

Use following command to program the prefix string in the dialed number string table:

151-Dialed Number String Table Index-Number String-#*

Where,

Dialed Number String Table Index is from 002-500. Number String at 001 is not programmable as it is reserved for the case if no match is found with the dialed number routing table.

Number String is of maximum 8 digits (0-9, #, *).

By default, Number String is Blank.

Use following command to clear number string in the dialed number string table:

151-Dialed Number String Table Index-#*

Step 2

Use following command to program the routing group in the dialed number string table:

152-Dialed Number String Table Index-Routing Group-#*

Where,

Dialed Number String Table Index is from 001 to 500.

Routing Group is from 01 to 16.

By default, Routing Group is 03 in the dialed number string table.

Step 3

Use following command to program the “Change Called Number?” flag at an index into the dialed number based routing table:

153-Dialed Number String Table Index-Code-#*

Where,

Dialed Number String Table Index = Index of Dialed Number table for which the “Change Called Number?” flag is to be set.

Index is from 001 to 500.

Code	Meaning
0	Donot change called number
1	Change called number

By default, Code = 0.

Step 4

Use following command to program new called number at an index in the dialed number table:

154-Dialed Number String Table Index-New Called Number-#*

Where,

Index of Dialed Number table is from 001 to 500.

New Called Number is the number of max. 16 digit, which will be replaced by the called number available, if any.

By default, All numbers are blank.

Use following command to clear the destination number string at an Index in the dialed based routing table:

154-Dialed Number Based Routing Table Index-#*

Step 5

Use following command to clear the entire dialed number string table:

155-#*

Example:

- Call is to be made on the some GSM SP number of Mumbai (301220) using routing group 07, then the dialed number string is programmed as (0223) and routing group number is programmed as 07 at index 002.
- If local calls made to Ahmedabad's number starting with 2.... using routing group number 08, then the Dialed Number String is programmed as (95792) and routing group number is programmed as 08 at index 003.
- If all international calls need to be routed through routing group 09, the dialed number string should be programmed as (00) and routing group number is programmed as 09 at index 004. The table may look as given below:

Index	Number String	Routing Group	Change Called Number?	New Called Number
001	Note¹	03	No	Blank
002	223	07	No	Blank
003	95792	08	No	Blank
004	00	09	No	Blank
:	:	:	:	:
500	Blank	03	No	Blank

Note¹:

The first row of the Table contains routing parameters used when No match is found with Calling Numbers programmed in the table. Hence 'Number String' is NOT programmable for Index-001. But 'Routing Group', 'Change Called Number?' and 'New Called Number' programmed at 1st index will be used if the match of Dialed Number is not found in the Dialed Number String Table.

Commands:

- 155-#*** (Clear entire table)
151-002-0223-#* (Program 0223 at index 2)
151-003-95793-#* (Program 95793 at index 3)
151-004-00-#* (Program 00 at index 4)
152-002-07-#* (Program a routing group 07 at index 2)
152-003-08-#* (Program a routing group 08 at index 3)
152-004-09-#* (Program a routing group 09 at index 4)

- 161-07-1-3-1-#*** (Program TE 1 port in routing group 07)
- 161-08-1-3-2-#*** (Program TE 2 port in routing group 08)
- 161-09-1-3-1-#*** (Program TE 1 port in routing group 09)
- 162-07-1-#*** (Assign selection a first free to routing group 07)
- 162-08-1-#*** (Assign selection a first free to routing group 08)
- 162-09-1-#*** (Assign selection a first free to routing group 09)

Relevant Topics:

1. Routing Group 124
2. Routing Type 131

=X=X=

Emergency Number Dialing

What's this?

- The user should be able to contact service personnel like Fire Brigade, Ambulance, etc. from ISDN and GSM network, when he is facing some adverse situation and needs some help. This is known as 'Emergency Number Dialing'.
- SIMADO GBR42 supports this feature for BRI and Mobile port. For ISDN network fixed emergency numbers can be dialed from the gateway, from any TE port. But for GSM network, it may happen that you need to call emergency number even when you have not inserted the SIM card and the module is not registered with the network. This is called 'False' status of the GSM port. Normally SIM card is inserted and the module is registered with the network. This is called 'True' status of the GSM port. SIMADO GBR42 supports the emergency dialing feature for both status of GSM port, just like a mobile handset.
- If required, user can program the number string using following Codes for the Special digits:

Special Digit	Code
Flash	#2
Pause	#3
A	#4
B	#5
C	#6
D	#7
+	#8
#	##

Warning!

- This feature will not work, if DC power to 12VDC jack fails.

How it works?

- The system supports 4 programmable numbers and routing group, which will be used as emergency numbers for dialing. Each number is of 4 digits maximum.
- The dialed number is compared with numbers programmed in the emergency number table. If it matches by perfect fit logic then the number is dialed out from the port, selected by routing logic using

the routing group programmed in the system.

- The destination port to route the call is determined as per the member selection method assigned to the routing group. The destination port can be BRI Port or Mobile.
- If the destination port, to route the call is found to be GSM, the GSM port will send the number to the GSM module for dialing out, even if the port is True or False.
- The system doesn't check the Allowed and Denied Lists or automatic Number Translation, for dialing the emergency number, but the port must be enabled.

Emergency dialing in GSM network is explained in detail as below:

- A Mobile station has two intelligent systems within itself viz. the GSM Engine and the SIM card.
- Both, the GSM engine and the SIM card classify few number strings as Emergency numbers. Such numbers are dialed by the module with a specific SET UP message known as Emergency Call Set Up message.
- These numbers are dialed by the GSM Engine in following cases:
 - Not registered with subscribed Service Providers' Network. In such case, the Engine dials the Emergency number using any other available GSM network.
 - When SIM is absent.
 - When SIM is invalid (Only few Emergency numbers are allowed. This depends on the GSM Engine).
 - When SIM is blocked.
 - When wrong SIM PIN is entered.
- For example, for a specific GSM Engine and a SIM Card from a Service Provider, following sequence is followed to dial an Emergency Number:
 - It will first search for emergency call number stored in the SIM phone book. If there is at least one emergency number in the SIM, it will search for the number. If does not match, it will search for 112 or 911.
 - If SIM does not have any emergency number stored it will search for the number in the default emergency number list stored in the firmware which are 000, 08, 112, 110, 911, 999.
 - If the SIM is invalid means either PUK1 Blocked or PUK2 Blocked or No SIM, it will search for emergency numbers, which are 000, 08, 112, 110, 911, 999, 118 and 119.

- If SIM is blocked means either PIN1 Blocked (PUK1 Requested) or PIN2 Blocked (PUK2 requested) valid emergency numbers are 000, 08, 112, 110, 911, 999.
- If SIM is not inserted 000, 08, 112, 110, 911, 999, 118 and 119 are considered as emergency numbers.
- If wrong PIN is entered 000, 08, 112, 110, 911, 999 are considered as emergency numbers.

How to program?

Step 1: To program emergency number in the emergency number table using command **731**.

Step 2: To program routing group for emergency number using command **732**.

Step 1

Use following command to program Emergency Number in the Emergency Number Table:

731-Index-Emergency Number-#*

Where,

Index is from 1 to 4.

Emergency Number is of maximum 4 digits, 0-9, #, * can be programmed.

Use following command to clear Emergency Number programmed at Index in Emergency Number Table

731-Index-#*

Where,

Index is from 1 to 4.

Default emergency number table is given below:

Index	Emergency Number
1	112
2	911
3	000
4	106

Step 2

Use following command to program Routing Group for the Emergency Number

732-Index-Routing Group-#*

Where,

Index is from 1 to 4.

Routing Group is from 1 to 16.

Default emergency number table is given below:

Index	Emergency Number	Routing Group
1	112	03
2	911	03
3	000	03
4	106	02

Important Points:

- The GSM port from where, the emergency number is to, be dialed should be enabled, even if it is 'False'.
- The number programmed, which are to be routed through GSM port as emergency number should exist as emergency number either in the GSM module, or in the SIM in the memory storage, which is classified as emergency number. For this information, contact your GSM Service Provider.

Relevant Topics:

1. Routing Group 124
2. Mobile Port Parameters 96

=X=X=

Fixed Dialing

What's this?

To avoid dialing of a station number or destination number which is frequently used, the Matrix system offers, a feature by which the user has to just pick up his handset and the system will automatically dial out the fixed destination number. This feature is called Fixed Dialing.

How it works?

- The feature can be enabled on Mobile, TE or NT port.
- When routing type 'Fixed' is programmed for the port, call will be routed to 'Fixed destination Number' programmed for the port after 'First Digit Wait Timer' is expired.
- Fixed destination number can be programmed on NT/TE/Mobile port.
- If fixed dialing is disabled and caller goes OFF-Hook, then caller will get 'Error Tone' on expiry of First Digit Wait Timer for NT port.

How to program?

Step 1: To enable/disable fixed dialing on a Mobile Port using command **631**.

Step 2: To program the fixed destination number for the Mobile Port using command **632**.

Step 3: To enable/disable fixed dialing on a TE Port using command **633**.

Step 4: To program the fixed destination number for the TE Port using command **634**.

Step 5: To enable/disable fixed dialing on a NT Port using command **635**.

Step 6: To program the fixed destination number for the NT Port using command **636**.

Step 1

Use following command to enable/disable fixed dialing on a mobile port:

631-Mobile Port-Code-#*

Where,

Mobile Port is from 1 to 4.

Code	Meaning
0	Disable
1	Enable

By default, Fixed Dialing is enabled on all the ports.

Step 2

Use following command to program the fixed dialing fixed destination number for the mobile port:

632-Mobile Port-Number String-#*

Where,

Mobile Port is from 1 to 4.

Number String is of 16 digits.

By default, the Number String is blank.

Step 3

Use following command to enable/disable fixed dialing on a TE Port:

633-TE Port-Code-#*

Where,

TE Port is from 1 to 2.

Code	Meaning
0	Disable
1	Enable

By default, Fixed Dialing is disabled on all the ports.

Step 4

Use following command to program the fixed destination number for the TE port:

634-TE Port-Number String-#*

Where,

TE Port is from 1 to 2.

Number String is of 16 digits.

By default, the Number string is blank.

Step 5

Use following command to enable/disable fixed dialing on a NT port:

635-NT Port-Code-#*

Where,

NT Port is from 1 to 2.

Code	Meaning
0	Disable
1	Enable

By default, Fixed Dialing is disabled on all the ports.

Step 6

Use following command to program the fixed destination number for the NT port:

636-NT Port-Number String-#*

Where,

NT Port is from 1 to 2.

Number String is of 16 digits, using digits (0-9), #, *.

By default, the Number String is blank.

Relevant Topics:

1. Call Processing in SIMADO GBR42 52
2. Routing Type 131
3. Routing Group 124

=X=X=

International Mobile Equipment Identity (IMEI)

What's this?

- It may happen that you loose the gateway or it is stolen. Very important personal information is stored and you don't want somebody to misuse it. To help the user, manufacturer of GSM Module provides a code known as International Mobile Equipment Identity (IMEI) which can be sent to the network operator. The operator will use it to put your GSM module of the specific gateway, in unoperational state. Thus, the IMEI code is used to identify an individual GSM Module. When gateway is switched ON, the IMEI code is transmitted and checked against a database with the network operator. The IMEI number is normally printed on the GSM Module (but for some modules, the number is programmed by Matrix and is pasted on the module).

How it works?

- When the GSM ports are initialized, the request for IMEI is sent on each GSM port by the Gateway. The GSM port responds with its IMEI number. This is stored by the Gateway application.
- This number can then be viewed through Jeeves on the Mobile IMEI page by clicking on the "Display" button.
- If the IMEI number is not obtained during initialization from any GSM port, then corresponding field in the Jeeves page will remain blank.

Important Point:

- Sometimes it may happen that module does not send the IMEI number during power ON. In such case, the user should restart the system.

Relevant Topic:

1. [Mobile Port Parameters](#) 96

=X=X=

ISDN-An Introduction

What's this?

SIMADO GBR42 is an efficient Gateway, which routes the call between GSM and ISDN network. This chapter is intended to provide the user with basic details of ISDN.

The ISDN Technology

ISDN stands for “Integrated Services Digital Network”. “**Integrated Services**” refers to ISDN’s ability to deliver two or more simultaneous connections, in any combination of data, voice, video, and fax, over a single line. “**Digital**” refers to ISDN’s purely digital transmission, as opposed to analog transmission of Plain Old Telephone System (POTS). ISDN transmits data digitally, resulting in a very clear transmission quality. “**Network**” refers to the fact that ISDN is not simply a point-to-point solution like a leased line. ISDN networks extend from the local telephone exchange to the remote user and include all the telecom and switching equipments in between.

ISDN is based around two types of channels:

- Bearer channel commonly called B-channel.
- Common Signaling channel commonly called D-Channel.

The Bearer Channel (B-Channel)

- The B-channels are logical “pipes” in a single physical ISDN line.
- The B-channel is a 64 Kbps clear channel whose entire bandwidth is available for user information since call setup. The user information can take several forms such as data or PCM encoded voice. One of the B-channels can be used for a device such as telephone or fax machine, while the other B-channel can be used for data transfer. Alternatively, two B-channels can be combined to download data at very high speeds to a PC.
- B-channels form circuit-switched connections, which resemble analog telephone connections in that they are end-to-end physical circuits temporarily dedicated to transfer information between two devices. The circuit-switched nature of B-channel connections, combined with their reliability and high bandwidth, makes ISDN suitable for voice, video, fax, and data applications.
- B-channels can be used to transfer any layer 2 or higher protocols

-
- across a link within the OSI model.
- Although B-channels are normally used for on-demand connections, taking full advantage of the circuit-switched networks upon which they are based, they can also be configured as semi-permanent or “nailed-up” connections, which are always “up”, much like a leased line. However, this can cause a capacity problem for carriers and ISPs, which can be solved by an emerging feature of ISDN called “Always On/Dynamic ISDN (AO/DI)”.

The Common Signaling Channel (D-Channel)

- Unlike B-channels, which function as “pipes”, the D-channel is associated with higher level protocols at layers 2 and 3 of the OSI model that form the packet-switched connections.
- D-channel uses packet-switched connections, which are best adapted to the intermittent but latency-sensitive nature of signaling traffic, thus accounting for the vastly reduced call setup time of 1 to 2 seconds. on ISDN calls (vs. 10 to 40 seconds using an analog modem)
- D-channel transmits at either 16 Kbps (for BRI) or 64 Kbps (for PRI).
- The D-channel is used mostly for administrative signaling, to instruct the carrier to set up or terminate a B-channel call, to ensure that a B-channel is available to receive a call, or to provide signaling information for features like CLIP, CLIR, COLP, COLR, etc.

Following two sketches show the call setup process in POTS and in ISDN network, given for comparative study.

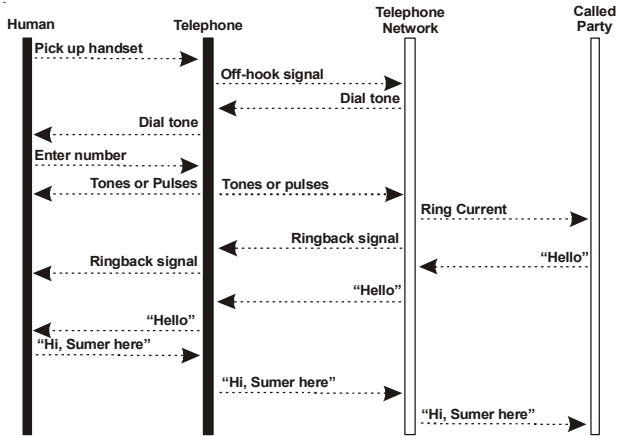

Call setup process in POTS

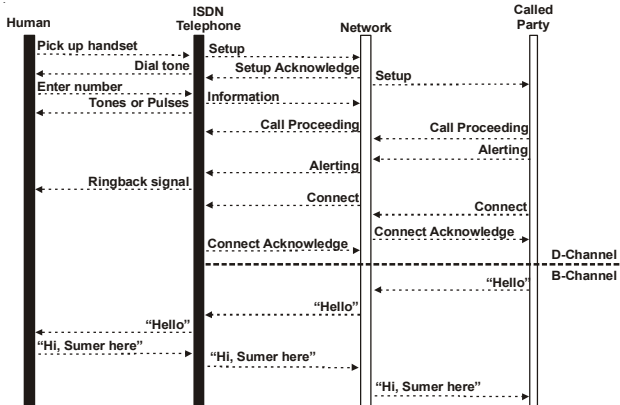

Call setup process in ISDN

Basic Rate Interface (BRI) ISDN

- The most common ISDN service is called Basic Rate or BRI. BRI is also referred to as 2B+D. Two B-channels carry data and services at 64 Kbps (or combine for 128 Kbps) whereas one D-channel carry signaling and administrative information at 16Kbps to set up and terminate calls.

- A BRI line consists of two B-channels, which can be viewed as two logical pipes supported by a D-channel as shown below.

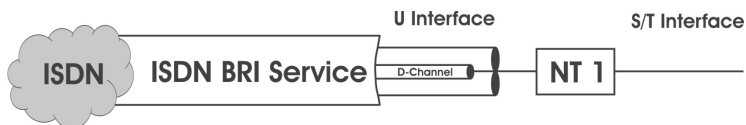

- BRI is intended to be the access point for customer premise equipment (CPE) such as ISDN telephones, ISDN Fax and other ISDN terminal equipment.
- Maximum Eight ISDN devices can be connected to this single physical line, and all the devices share the B-channels and D-Channel. Individual devices are distinguished through the use of Multiple Subscriber Numbers (MSNs), with a different ISDN number assigned to each device. D-channel signals automatically route communications to appropriate ISDN device.
- Point-to-Point BRI configuration and Point-to-Multipoint BRI configurations are shown below in the figure.



Point-to-Point BRI configuration

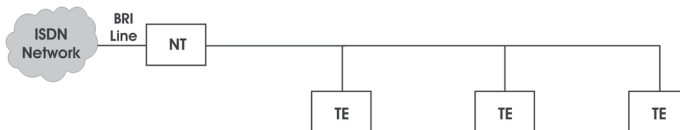

Point-to-Multi point short passive Bus BRI configuration

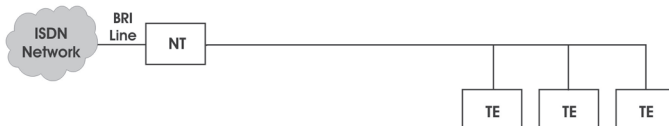

Point-to-Multi point extended passive Bus BRI configuration

- In a Point-to-Point physical configuration, the NT (NT1 or NT2) and the TE (TE1 or TA) can be up to 1 Km apart.
- There are two configurations possible in Point-to-Multipoint configuration viz. short passive bus configuration and extended

passive bus configuration. In case of short passive bus configuration, eight TEs can be connected to a single NT on a bus up to 200 meters. In extended passive bus configuration, multiple TEs are grouped together at one end of a bus, up to 1 km from the NT.

- Although only two B-channels are available at any point in time, numerous other calls can be put “on hold” via D-channel signaling, a feature referred to as “multiple call appearances”.
- BRI can be used in small offices to support all of its voice and data communication requirements. In a larger office, one or more BRI lines can be divided among multiple users and applications via a server or a PBX.

Primary Rate Interface (PRI) ISDN

- To support higher bandwidth requirements, ISDN is also available in primary rate or PRI (Primary Rate Interface). This service differs depending upon the region where it is deployed. In North America, Japan and Korea PRI supports 23B channels and one 64 Kbps D channel. In the rest of the world it provides 30B channels and one 64 Kbps D channel. These are referred to as 23B+D and 30B+D respectively.
- A PRI line consists of thirty B-channels, which can be viewed as thirty logical pipes supported by two D-channels as shown below. One of the D-channel is permanently used for framing, synchronization and other administrative purpose. Hence, the user has access to only D-channel for signaling.

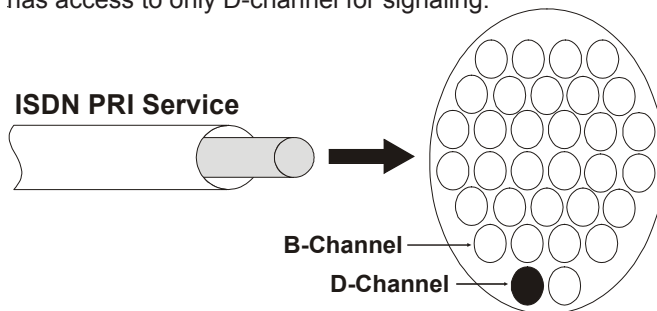

- Unlike BRI, PRI does not support a bus configuration i.e. multiple devices cannot be connected to a PRI line. However, a PBX can be used to reallocate PRI resources.

-
- A single PRI connection is usually much less expensive than obtaining the equivalent number of B-channels through multiple BRI connections
 - Primary benefit of PRI is that the bandwidth can be dynamically allocated among applications. E.g. certain channels can be allocated for voice calls, but as those calls are terminated, the unused B-channels can be reallocated to such high-bandwidth applications as video conferencing. This is usually accomplished via a PBX or a server capable of distributing the E1 bandwidth on a PRI link.

The ISDN Terminology

Various new terms used in context of ISDN are explained below.

ISDN functional devices and reference points:

The ISDN standards define several different types of devices. Each device type has certain functions and responsibilities but may not represent an actual physical piece of equipment. Hence these are called functional devices. The LE, NT1, NT2, TE1, TE2 and TA are examples of the functional devices.

Since functional devices do not work in isolation, there are several device-to-device interfaces, each requiring a communications protocol. Each of these device interfaces is called a reference point. The functional devices and reference points are explained below in detail.

Network Termination Type1 (NT1)

This functional device represents the termination of the physical connection between the customer site and the Local Exchange (LE). The NT1's responsibilities include line performance monitoring, timing, physical signaling protocol conversion, power transfer and the multiplexing of the B-Channel and D-Channel.

Network Termination Type2 (NT2)

These functional devices refer to those devices that provide customer site switching, multiplexing, and concentration. This includes PBXs, LANs, mainframe computers, terminal controllers and other CPE for voice and data switching. NT2 is generally absent in some ISDN environments, such as residential or Centrex ISDN service.

Matrix

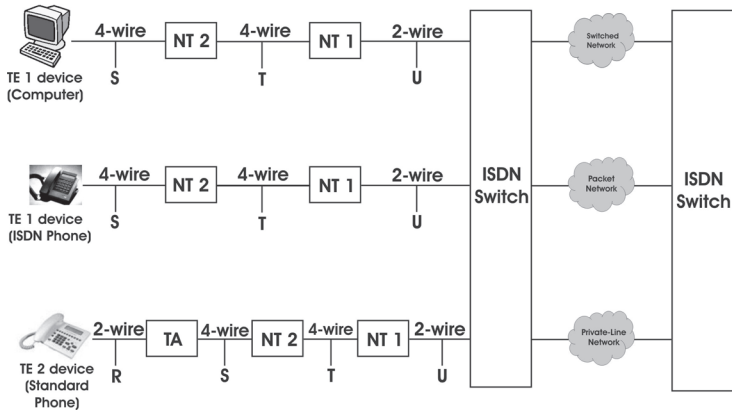

Terminal Equipment (TE) refers to end-user devices, such as an analog or digital telephone, X.25 data terminal equipment, ISDN workstation, or integrated voice/data terminal (IVDT).

Terminal Equipment Type1 (TE1) are those devices that utilize the ISDN protocols and support ISDN services, such as an ISDN telephone or workstation.

Terminal Equipment Type2 (TE2) are non-ISDN compatible devices, such as the analog telephones in use on today's telephone network.

Terminal Adaptor (TA) allows a non-ISDN device (TE2) to communicate with the network. TAs allow analog telephones, X.25 DTEs, PCs, and other non-ISDN devices to use the network by providing any necessary protocol conversation.

R reference point-It is the reference point between non-ISDN equipment and a TA.

S reference point-It is the reference point between ISDN user terminals (TE1/TA) and the network termination equipment (NT1/NT2)

T reference point-It is the reference point between customer site switching equipment (NT2) and the local loop termination (NT1). In absence of the NT2, the user network interface is usually called the

S/T reference point.

U-The reference point between NT1 devices and line-terminations equipment in the local exchange. The U reference point is relevant only in North America, where the NT1 function is not provided by the local exchange. In other countries, the ISDN service providers provide NT1 along with the services i.e. the U-interface is built in feature of the service. The customer gets S/T interface.

=X=X=

Jeeves

What's this?

- Programming a system through phones, is a bit time consuming process. The Matrix system provides a facility to program it using computer.
- Matrix supplies a customized, windows based software to program the SIMADO GBR42, known as Jeeves.
- The Jeeves is a flexible and friendly tool with mouse operated GUI.

How it works?

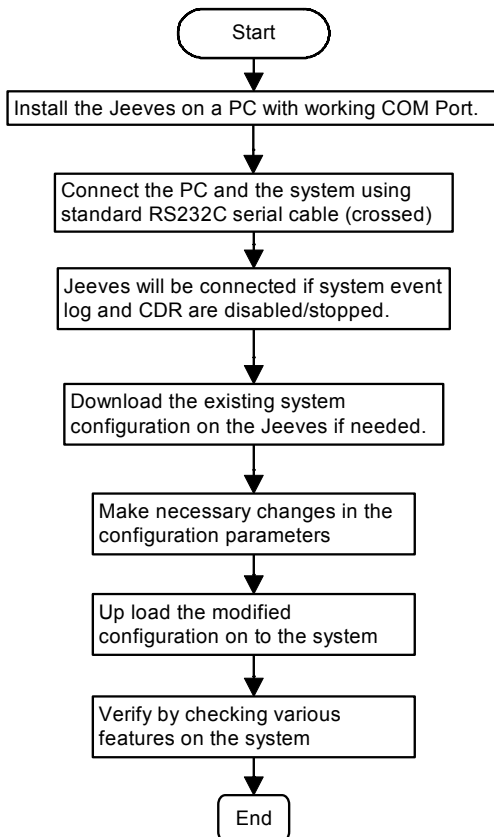

Important Point:

- If Jeeves is started on the COM port, user cannot get CDR report or debug through the commands. But from Jeeves, user can get report or debug.

Relevant Topics:

1. Communication Port 65
2. Programming the System 115
3. Configuring the System 16

=X=X=

Mobile Port Parameters

What's this?

- The GSM modules, used by the system need different setting for Rx audio level and Tx audio level, for required speech level at analog phones. For this, user has to optimize the gain of RF module.
- In order to interface Mobile ports with GSM network, few parameters are required to be programmed. The SIMADO GBR42 provides a facility in which mobile port parameters can be programmed for following parameters:
 - Enable/Disable Port.
 - Receive Gain.
 - Transmit Gain.
 - Inter Digit Wait Timer.
 - First Digit Wait Timer.
 - Allow/Deny IC Calls
 - Frequency Band
 - Signal Strength
 - DID

How to program?

Mobile Port parameters can be programmed in the following hierarchy:

Step 1: To enable/disable the Mobile Port using the command **301**.

Step 2: To set receive gain to the Mobile Port using the command **302**.

Step 3: To set transmit gain to the Mobile Port using the command **303**.

Step 4: To set First digit wait timer to the Mobile Port using the command **304**.

Step 5: To set Inter digit wait timer to the Mobile Port using the command **305**.

Step 6: To allow/deny IC calls for Mobile Port using command **308**.

Step 7: To program frequency band for Mobile port using command **309**.

Step 8: To request the signal strength of the mobile port using command **311**.

Step 9: To enable/disable DID on mobile port using command **671**.

Step 1

Port Enable/Disable-This command is used to disable a Mobile Port. Disabling Mobile Port is required in cases like Budget exhausted (Prepaid SIM card), Network problems, SIM problems, Hardware failure, etc. On disabling the port, No calls are possible through this port.

Use following command to enable/disable a mobile port:

301-Mobile Port-Code-#*

Where,

Mobile Port is from 1 to 4.

Code	Meaning
0	Disable
1	Enable

By default, all the ports are enabled.

Step 2

Receive Gain-This command is used to increase/decrease the receive Gain to improve the audibility of the incoming speech.

Use following command to program the receive gain of a mobile port:

302-Mobile Port-Receive Gain-#*

Where,

Mobile Port is from 1 to 4.

Receive Gain	Meaning
1	Very Low
2	Low
3	Normal
4	High
5	Very high

By default, Receive Gain is 3 for all ports.

Step 3

Transmit Gain-This command is used to increase/decrease the Transmit Gain to improve the output RF signal from the Gateway.

Use following command to program the transmit gain of a mobile port:

303-Mobile Port-Transmit Gain-#*

Where,

Mobile Port is from 1 to 4.

Transmit Gain	Meaning
1	Very Low
2	Low
3	Normal
4	High
5	Very high

By default, Transmit Gain is 3 for all ports.

Step 4

First Digit Wait Timer-This timer signifies the time for which the system waits after the user has gone OFF-Hook. On expiry of this time, system gives error tone.

Use following command to set first digit wait timer to the mobile port:

304-Mobile Port-First Digit Wait Timer-#*

Where,

Mobile Port is from 1 to 4.

First Digit wait timer is from 01 to 99 seconds.

By default, First digit wait timer is 10 seconds for all ports.

Step 5

Inter Digit Wait Timer-This timer signifies the time between two digits dialed on the port. On expiry of this timer, the Gateway considers it to be an end of string and proceeds with the call processing logic.

Use following command to set inter digit wait timer to the mobile port:

305-Mobile Port-Inter Digit Wait Timer-#*

Where,

Mobile Port is from 1 to 4.

Inter digit wait timer is from 01 to 99 seconds.

By default, inter digit wait timer is 05 seconds for all ports.

Step 6

- This gives option for allowing or denying the Incoming calls on this Port.
- If this option is set to “Deny”, the port can not be used as source port as all the call originating on this port will get rejected.
- If this option is set to “Allow”, the port can be used as source port. All the calls originating on this port will get routed based on the programming.
- If this port is ‘Destination Port’ this command is not applicable.

Use following command to allow/deny the Incoming Calls for Mobile Port:

308-Mobile Port-Code-#*

Where,

Mobile Port is from 1 to 4.

Code	Meaning
0	Deny
1	Allow

By default = 1 (Allow).

Note:

- Port must be 'enabled' to allow/deny IC Calls.

Step 7

Use following command for selection of Mobile Frequency Band on Mobile Port:

309-Mobile Port-Mobile Frequency Band

Where,

Mobile Port is from 1 to 4.

Mobile Frequency Band	Meaning
1	900
2	1800
3	1900
4	850 + 1900
5	900 + 1800

By default, Mobile Frequency Band = 900 + 1800.

For example, program 850 + 1900 GSM frequency band for countries which support both 850 and 1900 MHz frequencies for GSM network.

Step 8

Signal Strength

- Some times the Mobile port can not place the call on GSM network due to absence of signal or weak signal. Hence GBR42 supports to get the information about the Signal Strength when requested only from the BRI-NT Port using ISDN Phone or PBX connected to it. Using command from all the other ports like, Mobile or BRI-TE the user will get error tone.

- When user issues command from BRI NT and the Network responds it, the user will get confirmation tone and will get Numerical value of current signal strength. It is generally in the range if -113dBm to -51dBm.
- As the values are in –dBm, the ‘113’ represents weak signal, where as ‘51’ represents maximum signal strength. ‘0’ indicates absence of network.
- If from SE mode the command is issued for more than one mobile port then in such case, when SE comes out of SE mode, the signal strength of the Mobile port for which the last command is issued will be displayed. The command issued for other Mobile ports will get ignored. Hence it is advisable to request signal strength of one mobile port at a time.
- During response of the command, if CLI is not received on the BRI-NT port, the BRI-NT will place the dummy call as broadcast and all ISDN phones capable for receiving ‘blank’ will be ringing and will display the signal strength.

Use following command to request the Signal Strength of the Mobile port:

311-Mobile Port-#*

Where,

Mobile Port is from 1 to 4.

Step 9

Use the following command to enable/disable DID on Mobile port:

671-Mobile Port-Code-#*

Where,

Mobile Port is from 1 to 4.

Code	Meaning
0	Disable
1	Enable

By default, DID on Mobile Port is 0.

Important Point:

Network Response Timer-This timer signifies the time for which the system waits for a response from the network, after sending request for network parameters. This timer is fixed, 150 seconds, for all mobile ports.

Relevant Topics:

1. Call Proceeding Tone 49
2. Emergency Number Dialing 78
3. International Mobile Equipment Identity (IMEI) 85
4. Network Selection 102
5. SIM PIN 136
6. Remote Programming 118

=X=X=

Network Selection

What's this?

- Many times it happens that the system is installed in a remote place which is hilly or at a place where it is surrounded by multistoried buildings. In such case, the mobile user may not get registered with a suitable network and his work is affected. Same problem is faced when he is moving out of his home region. User of mobile station (Handset) has the user interface on the LCD, which shows, the name of the available network and he can select the desired network. But such user interface is not available in the SIMADO GBR42, gateway. The same purpose is served by providing multiple network operator options based on their specific network operator code. The subscriber can select the network manually or automatically, for each mobile port. This is known as Network Selection.
- If the subscriber is working in the area where, his home network as well as other network coverage is also available, then he can select the network manually such that he can restrict the extra charges. Normally subscriber uses this mode when he is working outside his home network.
- But if the subscriber is always busy with important business matter, then he would like to get registered with any network operator. He wants to make and receive calls, at any cost. For such requirement he will use this feature, in automatic mode.
- If required, user can program the number string using following Codes for the Special digits:

Special Digit	Code
Flash	#2
Pause	#3
A	#4
B	#5
C	#6
D	#7
+	#8
#	##

How it works?

- User can assign option for network selection to each mobile port he wants to use.
- The feature works, when SIMADO GBR42 is powered ON or if the port is NOT registered with network.
- Maximum 9 network operators can be programmed. In Manual Mode mobile port starts to get registered with network operator, as per order of programming with its network operator code. In Automatic Mode, the GSM port gets registered with the network operator as per field strength. If it doesn't get registered till expiry of network registration retry timer, it starts again the process of network selection.
- User should know the inter network call charges while programming priority network operator codes, for manual mode operation.
- Network operator code, consists of **MCC** and **MNC**.
- **MCC**: MCC is Mobile Country Code, which identifies a country. For a country, there can be more than one MCC. It is generally of 3 digits. For e.g. for India, MCC is 404, which is same for all networks in India.
- **MNC**: MNC is Mobile Network Code, which is same for all network operators in India. But it is different in each state for the same network operator. For e.g. Airtel-Gujarat, MNC is '98' and Airtel-Maharashtra, MNC is '90'. Thus, MCC-MNC combination uniquely identifies the home network of the mobile terminal. For example, MCC for other countries are as shown below:
 - USA : 310
 - Canada : 302
 - Australia : 505
 - Italy : 222

Default parameters programmed in the system is as shown below:

Mobile	Network Selection	Network Operator Code				
Port	Mode	Priority1	Priority2	Priority3	Priority9
1	Automatic	Blank			Blank
2	Automatic	Blank	...			Blank
3	Automatic	Blank	...			Blank
4	Automatic	Blank			Blank

How to program?

Step 1: To program network selection mode for the mobile port using command **721**.

Step 2: To program network operator code in priority for mobile port using command **722**.

Step 1

Use following command to program network selection mode for the Mobile port:

721-Mobile Port-Code-#

Where,

Mobile port is from 1 to 4.

Code	Meaning
1	Automatic
2	Manual

By default, Network Selection Mode is Automatic.

Step 2

Use following command to program network operator code in priority for Mobile port

722-Mobile Port-Priority Index-Network Operator Code-#*

Where,

Mobile Port is from 1 to 4.

Priority Index is from 1 to 9.

Network operator code is of maximum 16 digits, where digits from 0 to 9, #, * and alphanumeric characters can be programmed.

By default, Network Operator Codes for all the priority indices are blank.

Use following command to clear network operator code for Mobile port:

722-Mobile Port-Priority Index-#*

Where,

Mobile Port is from 1 to 4.

Priority Index is from 1 to 9.

Example:

A user feels call charges of network operator 'X' (MCC 404, MNC 98), will be the cheapest for his SIM card of home region. Second operator

'Y' (MCC 404, MNC 25) is cheaper, but the third operator 'Z' (MCC 404, MNC 21) is little cheap for call charges. Then program the network operator as per priority, as shown below:

He should program the SIMADO GBR42, for manual mode which doesn't depend on field strength of the network. He makes the call from mobile port 3.

721-3-2-#* (Network selection mode: Manual)

722-3-1-40498-#* (1st priority to network 'X')

722-3-2-40425-#* (2nd priority to network 'Y')

722-3-3-40421-#* (3rd priority to network 'Z')

Rest of priority are kept, blank.

Important Points:

- In manual mode, network is not selected as per the field strength but is selected as per the priority network codes, programmed for that mobile port.
- **Display of GSM Operator's ID:**
The gateway makes Query for the network operator's ID irrespective of the registration process is Manual or automatic for the Mobile port. This can be through Jeeves of the GBR42. The register ports will display their corresponding operator's code and unregistered ports will display 'Not Registered'.

Relevant Topic:

1. Mobile Port Parameters 96

=X=X=

NT Port Parameters

What's this?

- In order to utilize multiple extension of other PBX or to integrate an ISDN phone, the gateway should have some interface port. This is called NT port. The SIMADO GBR42 supports maximum of four NT channels.
- The SIMADO GBR42 provides a facility in which NT port can be programmed for parameters like:
 - Enable/Disable Port, Logical NT Port, Inter Digit Wait Timer, TON/NPI and other parameters.

How to program?

NT Port Parameters can be programmed in the following hierarchy:

Step 1: To enable/disable a NT port using command **501**.

Step 2: To assign a BRI hardware (physical) port to a NT logical port using command **502**.

Step 3: To set Inter digit wait timer for a NT port using command **504**.

Step 4: To program the ISDN Switch Variant for a NT port using command **505**.

Step 5: To program Overlap Receiving Timer for NT port using command **506**.

Step 6: To program the Idle Code for a NT port using command **510**.

Step 7: To allow/deny the IC calls for NT Port using command **511**.

Step 8: Program called party TON for NT port using command **513**.

Step 9: Program called party NPI for NT port using command **514**.

Step 10: Program calling party TON for NT port using command **515**.

Step 11: Program calling party NPI for NT port using command **516**.

Step 12: Select the TEI Negotiation Mode for NT port using command **517**.

Step 13: Program the TEI Negotiation Value for Fixed TEI Negotiation Mode using command **518**.

Step 1

Port Status (Enable/Disable)-This command is used to disable a NT port. It is required to disable the port in case no calls are to be initiated or terminated on this port. If disabled, the caller gets error tone, on accessing the port.

Use following command to enable/disable a NT port:

501-NT Port-Code-#*

Where,

NT Port is from 1 to 2.

Code	Meaning
0	Disable
1	Enable

By default, NT port is enabled.

Step 2

Software (Logical) Port-Hardware (Physical) Port Association-

This command is used to assign a BRI hardware (physical) port to a NT logical port.

Use following command to assign a BRI hardware (Physical) port to a NT logical port:

502-NT Port-BRI Port-#*

Where,

NT Port is from 1 to 2.

BRI Port is from 1 to 2.

By default, NT Port 1 is assigned BRI Hardware Port 1 and NT Port 2 is assigned BRI Hardware Port 2. Ensure that, jumper setting is as per the Port Type, programmed.

Any ISDN Terminal Equipment like ISDN Phone, ISDN PBX or ISDN Video Phone can be connected to this Port.

Step 3

Inter Digit Wait Timer-This timer signifies the time between two digits dialed on the port. On expiry of this timer, the Gateway considers it to be an end of string and proceeds with further call processing logic.

Use following command to program Inter digit wait timer for NT port:

504-NT Port-Inter Digit Wait Timer-#*

Where,

NT Port is from 1 to 2.

Inter digit wait timer is from 01 to 99 seconds.

By default, Inter Digit Wait Timer is 05 seconds.

Step 4

ISDN Switch Variant-Different countries use specific type of ISDN switch. This switch is designed using the protocol for ISDN standard or it can be a proprietary of manufacturing company of the switch. For example, France is using-French Delta and USA is using ISDN-1 (NI-1) type of switch. DMS-100 works as per proprietary protocol of Nortel. The SIMADO GBR42 supports only ETSI_NET3, for India.

Use following command to program the ISDN switch variant for a NT port:

505-NT Port-ISDN Switch Variant-#*

Where,

NT Port is from 1 to 2.

ISDN Switch Variant is 01 (ETSI_NET3).

By default, ISDN Switch Variant is '01'.

Step 5

Overlap Receiving Timer: This parameter is applicable only while receiving the called party number information in overlap receiving mode. It is not applicable for the port in overlap sending mode.

Use following command to program Overlap Receiving Timer for NT Port:

506-NT Port-Overlap Receiving Timer-#*

Where,

NT Port is from 1 to 2.

Overlap Receiving Timer is from 001 to 255 seconds.

By default, Overlap Receiving Timer is 15 seconds.

Step 6

Idle Code-It is a parameter used to signify that whether the channel is used or unused. For this, a specific binary code from 000 to 255 is sent on the channel. The Idle code for NT port should be programmed same as the 'TE Port'. The significance of this code is that, it is kept programmable as per the network, so that the network will consider the channel as idle, whenever it is idle.

Use following command to program the idle channel code for the NT port:

510-NT Port-Idle Code-#*

Where,

NT Port is from 1 to 2.

Idle Code is from 000 to 255.

Most commonly applicable values are 7F and FF (Binary equivalent is 0111 1111 and 1111 1111, decimal equivalent is 127 and 255).

By default, Idle Code is 127 (7F).

Step 7

- This gives option for allowing or denying the Incoming calls on this Port.
- If this option is set to “Deny”, the port can not be used as source port as all the call originating on this port will get rejected.
- If this option is set to “Allow”, the port can be used as source port. All the calls originating on this port will get routed based on the programming.
- If this port is ‘Destination Port’ this command is not applicable.

Use following command to allow or deny the Incoming Calls for NT Port:

511-NT Port-Code-#*

Where,

NT Port is from 1 to 2.

Code	Meaning
0	Deny
1	Allow

By default = 1 (Allow).

Note:

- Port must be ‘enabled’ to allow/deny IC Calls.

Step 8

Use following command to program ‘Called party TON’ for NT port:

513-NT Port-Called Party TON-#*

Where,

NT Port is from 1 to 2.

Called Party TON is from 1 to 7.

Called Party TON	Meaning
1	Unknown
2	International Number
3	National Number
4	N/w Specific Number
5	Subscriber Number
6	Abbreviated Number
7	Reserved Number

By default, Called Party TON is 'Unknown'.

Step 9

Use following command to program 'Called party NPI' for NT port:

514-NT Port-Called Party NPI-#*

Where,

NT Port is from 1 to 2.

Called Party NPI is from 1 to 7.

Called Party NPI	Meaning
1	Unknown
2	ISDN Number
3	Data Numbering
4	Telex Numbering
5	National Numbering
6	Private
7	Reserved

By default, Called Party NPI is 'ISDN Numbering'.

Step 10

Use following command to program 'Calling party TON' for NT port:

515-NT Port-Calling Party TON-#*

Where,

NT Port is from 1 to 2.

Calling Party TON is from 1 to 7.

Calling Party TON	Meaning
1	Unknown
2	International Number
3	National Number
4	N/w Specific Number
5	Subscriber Number
6	Abbreviated Number
7	Reserved Number

By default, Calling Party TON is 'Unknown'.

Step 11

Use following command to program 'Calling party NPI' for NT port:

516-NT Port-Calling Party NPI-#*

Where,

NT Port is from 1 to 2.

Calling Party NPI is from 1 to 7.

Calling Party NPI	Meaning
1	Unknown
2	ISDN Number
3	Data Numbering
4	Telex Numbering
5	National Numbering
6	Private
7	Reserved

By default, Calling Party NPI is 'ISDN Numbering'.

Step 12

TEI Negotiation Mode

- To integrate the Simado GBR42 with specific PBX type (e.g. Nortel PBX), the parameter TEI Negotiation mode should be 'fixed' instead of 'automatic'. Hence the GBR42 supports both options: Automatic and Fixed. If it is selected as 'Fixed' its value should be programmed.

Use following command to select TEI Negotiation on the NT port:

517-NT Port-TEI Negotiation Mode-#*

Where,

TE Port is from 1 to 2.

TEI Negotiation Mode	Meaning
1	Automatic
2	Fixed

By default, TEI Negotiation Mode is 'Automatic'

Note:

- GBR42 will get reset when TEI Negotiation Mode is changed for any port.

Step 13

TEI Negotiation Value

- Program the value if the TEI Negotiation Mode is selected as 'Fixed'.

Use following command to program TEI Negotiation value for the Fixed TEI Negotiation Mode:

518-NT Port-Value-#*

Where,

TE Port is from 1 to 2.

Value is from 00 to 63.

By default, TEI Negotiation value is 00 for both NT ports

Note:

- GBR42 will get reset when TEI value for fixed mode is changed for any port.
- TEI value programmed for BRI-NT port should match with the TEI value programmed in the Terminal Equipment connected with it.

Relevant Topics:

1. Configuring the System 16
2. TE Port Parameters 146

=X=X=

Number Lists

What's this?

- The Number Lists is group of number string. The SIMADO GBR42 use these lists to allow/deny a number to the port as well as for Automatic Number Translation.
- SIMADO GBR42 supports 16 Number lists.
- Each number list has 24 entries, which can be referred to as location.
- Number String in each location can be of maximum 16 digits long.
- If required, user can program the number string using following Codes for the Special digits:

Special Digit	Code
Flash	#2
Pause	#3
A	#4
B	#5
C	#6
D	#7
+	#8
#	##

Number List looks as given below:

Location Index/ No. List Index	01	02	03	24
01	Number String (16 digits)				
:					
:					
:					
:					
16					

How to program?

Step 1: To program a number string in a location index in the number list using command **121**.

Step 1

Use following command to program a number string in a location index in the number list:

121-List Number-Location Index-Number String-#*

Where,

List Number is from 01 to 16.

Location Index is from 01 to 24.

Number String is a string of maximum 16 digits (0-9, #, *, +).

Use following command to clear a location index in the number list:

121-List Number-Location Index-#*

Use following command to clear all the locations in the number list:

122-List Number-#*

Default Number list is given below:

	01	02	03	04	05	06	07	08	09	10	11	12	13	14-23	24
01	0	1	2	3	4	5	6	7	8	9	*	#	+	B	B
02	0	95	98	94	3	5	B	B	B	B	*	#	B	B	B
03	0	95	B	B	B	B	B	B	B	B	*	#	B	B	B
04	0	B	B	B	B	B	B	B	B	B	*	#	B	B	B
05	0	B	B	B	B	B	B	B	B	B	*	#	B	B	B
06	B	B	B	B	B	B	B	B	B	B	*	#	B	B	B
07	B	B	B	B	B	B	B	B	B	B	*	#	B	B	B
08-15	Same as 07														
16	B	B	B	B	B	B	B	B	B	B	*	#	B	B	B

Example:

If 0-dialing is to be barred, for a port, connected to the system, then a number list 04 can be programmed as:

122-04-#* (To clear all location)

121-04-01-0-#* (Program list with '0' prefix)

Relevant Topics:

1. Allowed and Denied List 33
2. Automatic Number Translation 38

=X=X=

Programming the System

What's this?

- SIMADO GBR42, supports two methods of programming:
 - Programming with analog phones, connected at NT ports.
 - Programming using Jeeves. Refer chapter [Jeeves](#) for this.
- This chapter explains how to enter programming mode for applying various commands.
- You can enter the programming mode:
 - From NT port directly (by dialing the command to enter System Engineer (SE) mode).
 - From TE/Mobile port if DID is enabled.

How to use it?

1	Lift the handset.	Dial tone
2	Dial *-19-SE Password.	Programming tone

To exit SE Mode, Dial **00-#***.

Use following command to change the SE Password:

211-New SE Password-#*

Where,

New SE Password is a number string of maximum 4 digits.

Important Points:

- While in programming mode if you go ON-Hook you will come out (exit) from the SE Mode. You will have to enter SE Mode again, to restart programming.
- The command is accepted even during confirmation tone.
- You will get programming tone on expiry of the confirmation tone.

Relevant Topics:

1. [Jeeves](#) 94
2. [Routing Type](#) 131
3. [Default the Configuration](#) 72
4. [Communication Port](#) 65
5. [Configuring the System](#) 16

=X=X=

Real Time Clock (RTC)

What's this?

- Various features and facilities provided by the gateway, use date and time parameters. These features are:
 - Defining four timezones in the table.
 - Routing type for the NT, TE and Mobile port for timezone.
 - Routing group for the NT, TE and Mobile port for timezone.
- Such facilities work properly only if the system is set with correct date and time values.
- For this SIMADO GBR42 is designed with built in Real Time Clock (RTC) circuit. This circuit is to be set once with current date and time values. It then updates itself regularly to keep track of the parameters.

However, please note that the RTC circuit can drift over a long period. Hence it is recommended to check and reset RTC values at least once every month to correct this drift. Please note that the system RTC takes care of the leap year.

How to program?

Step 1: To program the system date using command **101**.

Step 2: To program the Day of the week using command **102**.

Step 3: To program the system time using command **103**.

Step 1

Use following command to program the current date:

101-DD-MM-YYYY-#*

Where,

DD is from 01 to 31 (leading zero is must in case of single digit).

MM is from 01 to 12 (leading zero is must in case of single digit).

YYYY is from 0000 to 9999.

By default, Date is 01-01-2006.

Step 2

Use following command to program the day of the week:

102-Day-#*

Where,

Day is a single digit ranging from 1 to 7.

Day	Meaning
1	Sunday
2	Monday
3	Tuesday
4	Wednesday
5	Thursday
6	Friday
7	Saturday

By default, Day is 1.

Step 3

Use following command to program the current time:

103-HH-MM-SS-#*

Where,

HH is from 00 to 23 (leading zero is must in case of single digit).

MM is from 00 to 59 (leading zero is must in case of single digit).

SS is from 00 to 59 (leading zero is must in case of single digit).

By default, Time is 00:00:00.

Example:

An important application of RTC is for DST. User should set the system 'Time', 'Date' and 'Day' first using RTC, as per the current values, before programming the system for daylight saving time feature while installed in a country which observes DST.

Important Points:

- RTC parameters will not get defaulted, by issuing default GBR42 command.
- This will be defaulted only by loading new version and revision of the software.

Relevant Topic:

1. [Daylight Saving Time Adjustment](#) 67

=X=X=

Remote Programming

What's this?

- SIMADO GBR42 supports programming of Gateway from remote stations.
- The system can be programmed remotely from any port if the port is programmed for DID (Direct Inward Dialing). For explanation for DID, please refer '[Call Processing in SIMADO GBR42](#)'.
- When the call is answered by the Gateway, it prompts the caller to dial the code to enter the SE mode followed by SE password.
- The caller can start further programming of the system features.

Relevant Topics:

1. [Routing Type](#) 131
2. [Fixed Dialing](#) 82
3. [Mobile Port Parameters](#) 96
4. [TE Port Parameters](#) 146

=X=X=

Returned Calls to Original Callers (RCOC)

What's this?

- When a call is made to a mobile user and if he is found busy/not responding, the calling party's number gets stored in the memory of the mobile user. When the mobile user becomes free/available, he calls back the calling party and the call lands on the same extension of the calling party, who made this call through the gateway. This is called Return Calls to the Original Callers (RCOC).
- RCOC works only in following calls:
 - Source port is NT and destination port is Mobile.
 - Source port is Mobile and destination port is Mobile.
 - Source port is TE and destination port is Mobile.

How it works?

- When a call is made through a port, which is RCOC enable and if the called party is found busy/No Response/speech, then the called party number, calling party number (if available) and the calling port software number (call originating port number) is stored in a database.
- Now when the called party calls back, the calling party's number is compared with the previously called party's number in the RCOC database.
- If a match (Best Fit) is found, the call is placed to the same software port that made the call. Since best fit logic is used, the call is placed to the relevant port even if the calling party number does not match 100% with the called party of the OG call made by the gateway.
- The RCOC database is saved in configuration file so that it is not lost during power failure.
- Maximum 200 entries are allowed in the table.

The system contains database as shown below:

Called Party Number	Calling Party Number	Calling Port S/w Number
16 digits	16 digits	

- Typical cases of RCOC are given below for reference. These tables show how the entries will be made in the RCOC table by the system during various calls. These tables refer to the figure shown below:

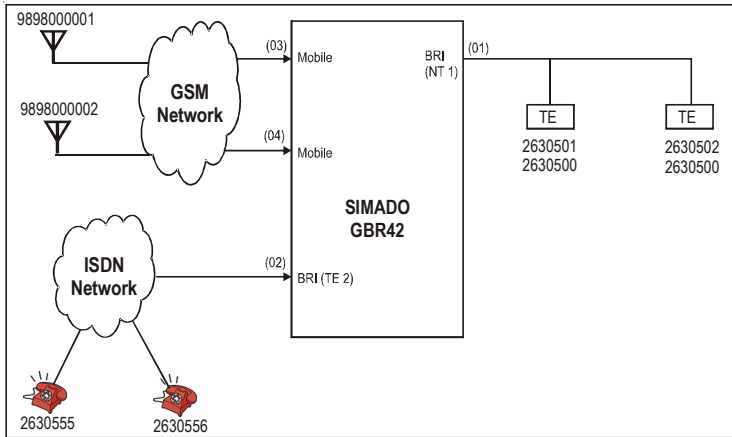

Case 1: NT to Mobile (2630501 to 9898000001)

- Call originates from NT Port and gets terminated on GSM network on 9898000001 using Mobile Port of the Gateway.

Calling Party Number	Called Party Number	Originating S/w Port Number
2630501	9898000001	01

Case 2: Mobile to Mobile (9898000001 to 9898000002)

- Call from GSM network (9898000001, External Number) comes on Mobile3 Port (originates on Mobile3 port of the Gateway), and gets routed on GSM Number 9898000002, using Mobile4 Port of the Gateway.

Calling Party Number	Called Party Number	Originating S/w Port Number
9898000001	9898000002	03

Case 3: TE to Mobile (2630555 to 9898000001)

- Call from external ISDN number 2630555 comes on TE port of the Gateway (call originates on TE port of the Gateway) and gets routed on external GSM number (9898000001) using Mobile Port of the Gateway.

Calling Party Number	Called Party Number	Originating S/w Port Number
2630555	9898000001	02

RCOC can be enabled/disabled for Busy, Speech and No Response Destinations (No Response includes No Reply, Switch Off, Reject and Out of Coverage).

How to program?

Step 1: To enable/disable RCOC for Busy destination on Mobile Port using command **601**.

Step 2: To enable/disable RCOC for No Response destination on Mobile Port using command **602**.

Step 3: To enable/disable RCOC for Speech destination on Mobile Port using command **603**.

Step 4: To program record delete timer using command **610**.

Step 5: To clear RCOC table using command **611**.

Step 1

Use following command to enable/disable RCOC for busy destination on mobile port:

601-Mobile Port-Code-#*

Where,

Mobile Port is from 1 to 4.

Code	Meaning
0	Disable
1	Enable

By default, RCOC for Busy destination on Mobile is Disabled.

Step 2

Use following command to enable/disable RCOC for no response destination on mobile port:

602-Mobile Port-Code-#*

Where,
Mobile Port is from 1 to 4.

Code	Meaning
0	Disable
1	Enable

By default, RCOC for No Response destination on Mobile is Disabled.

Step 3

Use following command to enable/disable RCOC for speech destination on mobile port:

603-Mobile Port-Code-#*

Where,
Mobile Port is from 1 to 4.

Code	Meaning
0	Disable
1	Enable

By default, RCOC for Speech destination on Mobile is Disabled.

Step 4

Record Delete Timer: This timer signifies the time after which the call is deleted from the table.

Use following command to program to record delete timer:

610-Record Delete Timer-#*

Where,
Record delete timer is from 001 to 999 minutes.

By default, Record delete timer is 999 minutes.

Step 5

Use following command to clear RCOC table:

611-#*

Example:

If a user wants to contact a person urgently. But his mobile number is busy. The number is dialed from mobile port 3 of the gateway. The user wants to retain all previous RCOC data only for next 12 hours. Then he should program the feature using following commands:

-
- 601-3-1-#*** (Enable RCOC on busy for mobile port 3)
610-720-#* (Record is deleted after 12 hours)

Important Points:

- Calling party and called party number are of 16 digits.
- After placing the call on the basis of RCOC, the corresponding entry is deleted from the database.
- While placing the call using RCOC, if it is found that the port on which the call is to be placed is busy, the call is routed using the logic as if RCOC is disabled.
- RCOC database is saved in configuration file so that it is not lost during power failure.
- *Storing Call Record:*
 - If the calling party number or the called party number is missing in the call record, then the record is not stored.
- *Deleting Call Record:*
 - The call record is deleted only after the call has been placed with the help of that record.
 - If the destination port is busy then the call is abandoned and the record is not deleted from the table.
 - The call record is deleted on expiry of the Record delete timer.

Relevant Topics:

1. Mobile Port Parameters 96
2. Real Time Clock 116

=X=X=

Routing Group

What's this?

- When a call is initiated from source port the system has to decide, from which port the call will be dialed out. These ports are grouped and specific number is assigned to that group. This is called Routing Group and is assigned to a port. The ports from the routing group are selected on the basis of member selection method assigned to each group.
- **Members and Member Selection Method:** The cases mentioned below explain how it is required to assign a Routing Group to NT, TE and Mobile Port and also how the members of the group are selected:
 - Many times it is required to call any of the person among a group of related people. It may not be important to talk to a particular person. In such a case, the routing group will contain only NT ports as members and routing type is selected as “Fixed”, which is assigned to TE/Mobile port. This is Originating port or Source port on which Incoming call is expected.
 - If for incoming call, landing on a NT port a Fixed Dialing Number has to be dialed out from a specific TE port or Mobile port then, that NT port is assigned a routing group, with routing type as “Fixed” and the TE or Mobile port are programmed as members.
 - The member ports of a routing group can be selected by rotation or first free method. If “Rotation Method” is selected, the fresh call will land on the destination next to the one, which received last call. This would enable equal distribution of incoming calls to all the destinations within the group.
 - If “First Free” is selected, the fresh call will always land on first port which is not busy. The system checks for free port starting from the first port in the group.

How it works?

- Maximum 16 routing groups can be formed.
- Maximum 8 members can be programmed in each routing group.
- Each port (Mobile, NT and TE) is assigned a routing group.
- Each member could be a Mobile Port, NT port or TE port.

How to program?

Step 1: To program a routing group table using command **161**.

Step 2: To assign member selection method for a routing group table using command **162**.

Step 3: To assign a routing group to a Mobile port for timezone 1 to 4 using command **681** to **684**.

Step 4: To assign a routing group to a TE port for timezone 1 to 4 using command **685** to **688**.

Step 5: To assign a routing group to a NT port for timezone 1 to 4 using command **689** to **692**.

Step 1

Use following command to program a routing group table:

161-Routing Group-Member Index-Port Type-Port Number-#*

Where,

Routing Group is from 01 to 16.

Member Index is from 1 to 8.

Port Type	Meaning	Port Number
0	Blank	0
1	Mobile	1-4
2	NT	1-2
3	TE	1-2

Default Routing Group is given below:

Matrix

RG No.	Member Selection Method	M1		M2		M3		M4		M5		M6		M7		M8	
		PT	PN	PT	PN	PT	PN	PT	PN	PT	PN	PT	PN	PT	PN	PT	PN
01	Rotation	NT	1	NT	2	B	B	B	B	B	B	B	B	B	B	B	B
02	Rotation	TE	1	TE	2	B	B	B	B	B	B	B	B	B	B	B	B
03	Rotation	M	1	M	2	M	3	M	4	B	B	B	B	B	B	B	B
04	Rotation	NT	1	B	B	B	B	B	B	B	B	B	B	B	B	B	B
05	Rotation	NT	2	B	B	B	B	B	B	B	B	B	B	B	B	B	B
06	Rotation	TE	1	B	B	B	B	B	B	B	B	B	B	B	B	B	B
07	Rotation	TE	2	B	B	B	B	B	B	B	B	B	B	B	B	B	B
08	Rotation	M	1	M	2	B	B	B	B	B	B	B	B	B	B	B	B
09	Rotation	M	3	M	4	B	B	B	B	B	B	B	B	B	B	B	B
10	Rotation	B	B	B	B	B	B	B	B	B	B	B	B	B	B	B	B
11	Rotation	B	B	B	B	B	B	B	B	B	B	B	B	B	B	B	B
12	Rotation	B	B	B	B	B	B	B	B	B	B	B	B	B	B	B	B
13	Rotation	B	B	B	B	B	B	B	B	B	B	B	B	B	B	B	B
14	Rotation	B	B	B	B	B	B	B	B	B	B	B	B	B	B	B	B
15	Rotation	B	B	B	B	B	B	B	B	B	B	B	B	B	B	B	B
16	Rotation	B	B	B	B	B	B	B	B	B	B	B	B	B	B	B	B

Where, PT = Port Type, PN= Port Number, M=Mobile and RG-Routing Group, B = Blank.

Step 2

Use following command to assign member selection method for a routing group:

162-Routing Group-Member Selection Method-#*

Where,

Routing Group is from 01 to 16.

Member Selection Method	Meaning
1	First Free
2	Rotation

By default, Member Selection Method is '2'.

- *First Free*: First free port is selected.
- *Rotation*: Always the N+1th port is selected, where N is the port on which last call was made.

Step 3

Use following command to assign a routing group to a mobile port for timezone 1:

681-Mobile Port-Routing Group-#*

Where,
Mobile Port is from 1 to 4.
Routing Group is from 01 to 16.

By default, RG '01' is assigned to all the Mobile Ports.

Use following command to assign a routing group to a mobile port for
timezone 2:

682-Mobile Port-Routing Group-#*

Where,
Mobile Port is from 1 to 4.
Routing Group is from 01 to 16.

By default, Routing Group '01' is assigned to all the Mobile Ports.

Use following command to assign a routing group to a mobile port for
timezone 3:

683-Mobile Port-Routing Group-#*

Where,
Mobile Port is from 1 to 4.
Routing Group is from 01 to 16.

By default, Routing Group '01' is assigned to all the Mobile Ports.

Use following command to assign a routing group to a mobile port for
timezone 4:

684-Mobile Port-Routing Group-#*

Where,
Mobile Port is from 1 to 4.
Routing Group is from 01 to 16.

By default, Routing Group '01' is assigned to all the Mobile Ports.

Step 4

Use following command to assign a routing group to a TE port for
timezone 1:

685-TE Port-Routing Group-#*

Where,
TE Port is from 1 to 2.
Routing Group is from 01 to 16.

By default, Routing Group '01' is assigned to all the TE ports.

Use following command to assign a routing group to a TE port for timezone 2:

686-TE Port-Routing Group-#*

Where,

TE Port is from 1 to 2.

Routing Group is from 01 to 16.

By default, Routing Group '01' is assigned to all the TE ports.

Use following command to assign a routing group to a TE port for timezone 3:

687-TE Port-Routing Group-#*

Where,

TE Port is from 1 to 2.

Routing Group is from 01 to 16.

By default, Routing Group '01' is assigned to all the TE ports.

Use following command to assign a routing group to a TE port for timezone 4:

688-TE Port-Routing Group-#*

Where,

TE Port is from 1 to 2.

Routing Group is from 01 to 16.

By default, Routing Group '01' is assigned to all the TE ports.

Step 5

Use following command to assign a routing group to a NT port for timezone 1:

689-NT Port-Routing Group-#*

Where,

NT Port is from 1 to 2.

Routing Group is from 01 to 16.

By default, Routing Group '03' is assigned to all the NT ports.

Use following command to assign a routing group to a NT port for timezone 2:

690-NT Port-Routing Group-#*

Where,

NT Port is from 1 to 2.

Routing Group is from 01 to 16.

By default, Routing Group '03' is assigned to all the NT ports.

Use following command to assign a routing group to a NT port for timezone 3:

691-NT Port-Routing Group-#*

Where,

NT Port is from 1 to 2.

Routing Group is from 01 to 16.

By default, Routing Group '03' is assigned to all the NT ports.

Use following command to assign a routing group to a NT port for timezone 4:

692-NT Port-Routing Group-#*

Where,

NT Port is from 1 to 2.

Routing Group is from 01 to 16.

By default, Routing Group '03' is assigned to all the NT ports.

Example:

- To assign NT1, the routing group number 8 which has four ports TE1, TE2, Mobile1 and Mobile2 with member selection method on first free during time 09:00 to 10:00.
- Program routing group 9 which has Mobile2, Mobile1, TE2 and TE1 ports, as members and assign to NT1 during timezone 15:00 to 18:00.

Solution:

Set the RTC

105-3-1-0900-1000-#* (Program the Timezone)

105-3-2-1001-0259-#*

105-3-3-1500-1800-#*

105-3-4-1800-0859-#*

108-1-3-#* (Assign timetable 3 to NT1)

161-08-1-3-1-#* (Program Routing Group Number 08)

161-08-2-3-2-#*

161-08-3-1-1-#*

161-08-4-1-2-#*

161-09-1-1-2-#* (Program Routing Group Number 09)

161-09-2-1-1-#*

161-09-3-3-2-#*

161-09-4-3-1-#*

162-08-1-#* (Assign member selection method)

162-09-1-#*

689-1-08-#* (Assign Routing Group 08 to NT1 for Timezone 1)

691-1-09-#* (Assign Routing Group 09 to NT1 for Timezone 3)

Relevant Topics:

1. Routing Type 131
2. Fixed Dialing 82
3. Real Time Clock 116
4. Time Table 159

=X=X=

Routing Type

What's this?

- The SIMADO GBR42 provides a facility to select various types of routing a call originated on a source port. This is called 'Routing Type'.
- Specific call routing type can be assigned to Mobile, TE and NT port for specific timezone.
- When call originates on source port, time table assigned to source port is checked, to determine call routing type for the timezone.
- If call origination time does not match any of the timezone of the time table, assigned to source port, call routing type programmed for the timezone 1 is selected.
- A Call can be routed based on following options:
 - Fixed.
 - Dialed Number Based.
 - Calling Party Number Based.
- **Fixed**-Selected when calls originating on the source port are to be routed to the programmed destination number as per the fixed routing group and member selection method assigned.
- **Dialed Number Based**-Used when routing on basis of the number dialed is required.
- **Calling Party Number Based**-If this is selected, the system will use calling party based routing table to determine the destination followed by routing group and member selection method to route the call. If matching entry is not found in calling party number table, then 'Fixed' routing group, programmed on the system is used to route the call.

The logic is explained by the flow chart in chapter '[Call Processing in SIMADO GBR42](#)' and programming is illustrated at the end of chapter.

How to program?

- Step 1:** To program a routing type for timezone 1 to 4 for the Mobile port using command **651** to **654**.
- Step 2:** To program a routing type for timezone 1 to 4 for the TE port using command **655** to **658**.
- Step 3:** To program a routing type for timezone 1 to 4 for the NT port using command **659** to **662**.

Step 1

Use following command to program a routing type for the mobile port for timezone 1:

651-Mobile Port-Routing Type-#*

Where,

Mobile Port is from 1 to 4.

Routing Type	Meaning
1	Fixed
2	Dialed Number Based
3	Calling Party Number Based

By default, Routing Type is '1'.

Use following command to program a routing type for the mobile port for timezone 2:

652-Mobile Port-Routing Type-#*

Where,

Mobile Port is from 1 to 4.

Routing Type	Meaning
1	Fixed
2	Dialed Number Based
3	Calling Party Number Based

By default, Routing Type is '1'.

Use following command to program a routing type for the mobile port for timezone 3:

653-Mobile Port-Routing Type-#*

Where,

Mobile Port is from 1 to 4.

Routing Type	Meaning
1	Fixed
2	Dialed Number Based
3	Calling Party Number Based

By default, Routing Type is '1'.

Use following command to program a routing type for the mobile port for timezone 4:

654-Mobile Port-Routing Type-#*

Where,

Mobile Port is from 1 to 4.

Routing Type	Meaning
1	Fixed
2	Dialed Number Based
3	Calling Party Number Based

By default, Routing Type is '1'.

Step 2

Use following command to program a routing type for the TE port for timezone 1:

655-TE Port-Routing Type-#*

Where,

TE Port is from 1 to 2.

Routing Type	Meaning
1	Fixed
2	Dialed Number Based
3	Calling Party Number Based

By default, Routing Type is '1'.

Use following command to program a routing type for the TE port for timezone 2:

656-TE Port-Routing Type-#*

Where,

TE Port is from 1 to 2.

Routing Type	Meaning
1	Fixed
2	Dialed Number Based
3	Calling Party Number Based

By default, Routing Type is '1'.

Use following command to program a routing type for the TE port for timezone 3:

657-TE Port-Routing Type-#*

Where,

TE Port is from 1 to 2.

Routing Type	Meaning
1	Fixed
2	Dialed Number Based
3	Calling Party Number Based

By default, Routing Type is '1'.

Use following command to program a routing type for the TE port for timezone 4:

658-TE Port-Routing Type-#*

Where,

TE Port is from 1 to 2.

Routing Type	Meaning
1	Fixed
2	Dialed Number Based
3	Calling Party Number Based

By default, Routing Type is '1'.

Step 3

Use following command to program a routing type for the NT port for timezone 1:

659-NT Port-Routing Type-#*

Where,

NT Port is from 1 to 2.

Routing Type	Meaning
1	Fixed
2	Dialed Number Based

By default, Routing Type is '1'.

Use following command to program a routing type for the NT port for timezone 2:

660-NT Port-Routing Type-#*

Where,

NT Port is from 1 to 2.

Routing Type	Meaning
1	Fixed
2	Dialed Number Based

By default, Routing Type is '1'.

Use following command to program a routing type for the NT port for timezone 3:

661-NT Port-Routing Type-#*

Where,

NT Port is from 1 to 2.

Routing Type	Meaning
1	Fixed
2	Dialed Number Based

By default, Routing Type is '1'.

Use following command to program a routing type for the NT port for timezone 4:

662-NT Port-Routing Type-#*

Where,

NT Port is from 1 to 2.

Routing Type	Meaning
1	Fixed
2	Dialed Number Based

By default, Routing Type is '1'.

Example:

To program NT1 port for call routing type 'Fixed' in 09:00 to 10:00 and routing type 'Dialed Number Based' in 15:00 to 18:00.

105-3-1-0900-1000-#* (Program Timezone)

105-3-2-1000-0259-#*

105-3-3-1500-1800-#*

105-3-4-1800-0859-#*

108-1-3-#*

(Assign Timetable 3 to NT1)

659-1-1-#*

(Assign Routing Type Fixed to NT1 for TZ1)

661-1-3-#*

(Assign Routing Type 'Dialed Number Based' to NT1, for Timezone 3)

Relevant Topics:

1. [Routing Group](#) 124
2. [Time Table](#) 159
3. [Real Time Clock](#) 116
4. [Call Processing in SIMADO GBR42](#) 52

=X=X=

SIM PIN

What's this?

Subscriber Identification Module (SIM) is a removable plastic card and contains an integrated IC chip with a microprocessor, RAM and ROM.

- The SIM is a smart card containing all subscriber specific data stored in it.
- A programmed (default) PIN (Personal Identification Number) is stored on the SIM.
- SIM PIN is a security feature used by the GSM network.
- If the user enters wrong SIM PIN three times in a row, the network suspects the user and asks for the Personal Unlock Keyword (PUK).
- If required, user can program the number string using following Codes for the Special digits:

Special Digit	Code
Flash	#2
Pause	#3
A	#4
B	#5
C	#6
D	#7
+	#8
#	##

How it works?

Refer '[Getting Started](#)' for more details.

How to program?

Use following command to program new SIM PIN:

712-Mobile Port-New SIM PIN-#*

Where,

Mobile Port is from 1 to 4.

New SIM PIN is of 4 to 8 digits maximum.

By default, SIM PIN is 1234.

Important Points:

- If PIN of the SIM is changed to more than 4 digits in the SIMADO GBR42, it will be possible that if such SIM is inserted in the Mobile Set, the Mobile Set will not allow it, because some Mobile Sets support PIN length of four digits only. In such condition the user should first change the PIN using SIMADO GBR42 to four digits and then insert it into the Mobile Set.
- Ensure that 'SIM PIN at Power ON' in SIM Card is enabled. Else SIM PIN will not be changed using this command.
- SIM PIN number does not get default when the user gives the command to default the SIMADO GBR42 parameters. PIN values get default to 1234, only when the Version or Revision number of the software of the SIMADO GBR42 is changed.

Relevant Topic:

1. Mobile Port Parameters 96

=X=X=

Software Version/Revision Display

What's this?

- Matrix updates its products for upgradation and better performance of some features. Hence the user may like to know the current software version installed in his gateway.
- This information is available only through Jeeves.

Important Points:

- The display in Jeeves is in the form shown below:

VxRy

Where,

x : Software Version Number.

y : Software Revision Number.

Relevant Topic:

1. NT Port Parameters 106

=X=X=

System Event Log

What's this?

- Matrix SIMADO GBR42 supports generation of log of events related to port states and activities for all the ports.
- This will be helpful to SE if any trouble shooting/debugging is required.
- The event log feature can be enabled/disabled for each port: BRI-TE and BRI-NT. It is programmable for Mobile port.
- The GBR42 will send the 'event', based on the activities for each port. These events are grouped in different levels and each event of the level is selected using specific code.
- The SE command can be given from any port from SE mode.

How it works?

- When event logging process is started, the events sent by the SIMADO GBR42 gets logged in the 'Text File' at path specified from Jeeves button 'Capture Event Log',
- When capturing is ON, and during this period if SE try to open the log file, he can not see the event online in this file. When SE stops the event logging process then only he will be able to see the events captured during the event logging process.
- SE can select 'Type of Event Logging' for each Mobile port.
- Event logging process can be stopped by issuing the specific command.
- The events will not get stored in the SIMADO GBR42.
- When SE restarts the 'Simado GBR42', the Event Logging process will be stopped (even if started before). SE will have to start the event logging process again if required.

How to program?

Step 1: To enable/disable event logging for system call events using command **231**.

Step 2: Select the type of event logging for the mobile port using command **306**.

Step 3: To enable/disable the type of events to be logged for each level on BRI-TE port using command **417**.

Step 4: To enable/disable the type of events to be logged for each level on BRI-NT port using command **512**.

Step 5: To Start/Stop event logging Process.

Step 1

Use following command to enable/disable event logging for system call events:

231-Code

Where,

Code	Meaning
0	Disable
1	Enable

By default, It is Disabled.

System call event includes events related to calls originated/terminated from each port. This is useful to know call routing.

Step 2

Use following command to select the Type of event logging for the Mobile port:

306-Mobile Port-Code

Where,

Mobile Port is from 1 to 4.

Code	Meaning
0	Disable
1	Library Layer
2	Module Layer
3	Library + Module Layer

Default Event Logging is 'Disable' for all the Mobile Ports.

Step 3

Use following command to enable/disable the type of events to be logged for each level on BRI-TE port:

417-TE Port-Level-Code-#*

Where,

BRI TE Port is from 1 to 2.

Level is from 1 to 4.

Code is from 000 to 255

By default, 000 (disable) for all levels.

Step 4

Use following command to enable/disable the type of events to be logged for each level on BRI-NT port:

512-NT Port-Level-Code-#*

Where,

BRI TE Port is from 1 to 2.

Level is from 1 to 4.

Code is from 000 to 255.

By default, 000 for all levels.

Level and Code for events of BRI-NT and BRI-TE port are as below:

Level 1

Unused	Flow	NLS	LAP	SVC Primitives	Variables	State	Primitives
--------	------	-----	-----	-------------------	-----------	-------	------------

Code for Level 1

001	Primitives
002	State
004	Variables
008	SVC Primitives
016	LAP
032	NLS
064	Flow Debug
000	Event logging Off

Level 2

Unused	Unused	Unused	DTMF digit	Unused	Layer 4	Unused	Unused
--------	--------	--------	---------------	--------	---------	--------	--------

Code for Level 2

004	Layer 4
016	DTMF Digit
000	Event logging Off

Level 3

Unused	Unused	Unused	HDLCD- Channel	Unused	Unused	Unused	Unused
--------	--------	--------	-------------------	--------	--------	--------	--------

Code for Level 3

016	HDLC (D Channel)
000	Event logging Off

Level 4

Unused	Unused	Unused	Unused	Unused	Unused	OS Task	NI
--------	--------	--------	--------	--------	--------	---------	----

Code for Level 4

001	Network Interface (NI)
002	OS Task
000	Event logging Off

For Example:

- When '004' decimal value is entered as Debug Code for 'Level 1', then its binary equivalent '100' indicates that event logging for **“Variables”** will get enabled.
- If “007” decimal value is entered as a debug code for the 'Level 1', then its binary equivalent “111” indicates that event logging for **“Primitives”, “States”** and **“Variables”** will get enabled.

Step 5

Refer chapter '[Communication Port](#)' to Start/Stop event logging Process (debug):

Relevant Topics:

1. [Mobile Port Parameters](#) 96
2. [TE Port Parameters](#) 146
3. [NT Port Parameters](#) 106
4. [Communication Port](#) 65

=X=X=

System Parameters

What's this?

A Law/Mu Law:

- Some parameters of the Gateway are not to be programmed for the specific Mobile, NT or TE port. These are programmed as System Parameters. For example, a companding method is programmed for the gateway.
- Companding is a method of improving the signal-to-noise (S/N) ratio resulting from the pulse code modulation (PCM) process on voice calls. The analog signal's amplitude is compressed before it is quantized and transmitted. Either of two algorithms are used to compand voice band signals for a specific country: A-Law or Mu-Law.
- For India A-Law will be programmed.

Replacing '+' by digits in CLI:

- The GSM network usually presents the calling party number with prefix as '+', to the called party. On receipt of call on Mobile port, few terminal equipments are unable to represent the calling party number if it contains '+'.
• Hence, the Matrix GBR42 supports the command, to replace '+' of the CLI number, with the programmable digits and is presented on the terminal equipment connected on the BRI-NT/TE as applicable.
- '+' can be replaced with maximum 6 digits.

End of Dialing Digit:

- End of dialing digit is a mechanism by which end of number string is interpreted by the system and processing for out dialing is faster.
- User can decide whether to use '#' as end of dialing digit, using specific command.
- If end of dialing flag is set, the GBR42 will consider '#' as end of dialing digit and if '#' is dialed as the First Digit, it will not be considered as end of dialing digit.
- When IDWT (Inter Digit Wait Timer) expires it will also be considered as end of dialing.

How to program?

Step 1: To select A-law and mu-law for the gateway using command

109.

Step 2: To configure the GBR42 to strip the '+' or not from the received calling party number using command **216**.

Step 3: To program the Replacement String which should be used to replace '+' in the CLI using command **217**.

Step 4: Program to use # as end of dialing digit using command **141**.

Step 1

Use following command to select A-law and mu-law for the Gateway:

109-PCM Selection-#*

Where,

PCM Selection	Meaning
1	A-Law
2	Mu-Law

By default, PCM Selection is A-Law.

Step 2**Replacing '+'**

Use following command, to configure the GBR42 to strip the '+' or not from the received calling party number:

216-Code-#*

Where,

Code	Meaning
0	Do not make any modification in received CLI.
1	Replace '+' from the CLI with the programmed replacement string.

By default the option is 'Do not make any modification in received CLI'.

Step 3:**Replacement String**

Use following command to program the Replacement String which should be used to replace '+' in the CLI:

217-Replacement String-#*

Where,

Replacement String = Digits from 0 to 9 and Blank, with 6 digits max.

By default, 'Replacement string' is Blank.

Use following command to program blank as the replacement string:
217-#*

Note:

- Using this command, the '+' character can be eliminated from the received CLI string.

Step 4

End of Dialing Digit

Use following command to use # as end of dialing digit:

141-Code-#*

Where,

Code	Meaning
1	Use # as end of dialing digit
0	Do not use # as end of dialing digit

By default, '# is used as end of dialing digit (Code=1).

Related Topics:

1. [Time Table](#) 159
2. [Real Time Clock](#) 116

=X=X=

TE Port Parameters

What's this?

- In order to utilize BRI trunk of other PBX or to integrate with ISDN network or to ISDN private network through the NT1 (provided by the Service Provider) the gateway should have some interface port. This is called TE port. The SIMADO GBR42 supports maximum of four TE channels.
- For expected performance of the gateway, some parameters are programmed for the TE port.
- SIMADO GBR42 facilitates programming of Enable/Disable of the port, Logical TE port, Timers, TON/NPI and other parameters.

How to use SPID?

- SPID is 'Service Provider Identifier', when the customer purchases a BRI line (in North America), the service provider will assign 2 SPIDs (one for each B-channel) or 8 SPIDs and the equivalent number of Directory numbers.
- In either case, the GBR42 will use only one SPID.
- Since the ISDN terminals are connected to the BRI-NT port of the GBR42, these are not identified by the network directly.
- In accordance with Q.932 standards, the GBR42 uses the Directory numbers to route the IC calls to the respective BRI terminal.
- Whereas for OG calls, the GBR42 uses only one USID (User Service Identifier) and TID (Terminal Identifier) received from the network while initializing with the network.
- As per the protocol, for each SPID number sent by the ISDN terminal to the N/w, a USID and a TID is assigned to the ISDN terminal by the network. For all future communication from the Terminal to the N/w, the USID and the TID numbers are used by the ISDN Terminal.
- The network on receipt of each call scans the USID and TID and then depending on this information allows/denies the call. For e.g. a customer purchases a BRI line from the N/w and asks for two SPIDs from the N/w, one for Data and other for Speech. The customer connects two Terminal Equipments viz. an ISDN data terminal and an ISDN phone. The customer programs the SPIDs in the respective terminals. The user can send the data using Voice

SPID. This will send the data even faster because speech calls are handled in real time by the network. However, the Voice SPIDs are costly.

Type of Network

- This parameter is supported by Matrix GBR42, to take care of the calls which are originated from Mobile port and to be routed to TE Port of the gateway when the gateway is interfaced with the PBX.
- This is because there is no provision to send a valid calling party number (consisting of set of ISDN Numbers allocated by the exchange) while placing the call from TE Port.
- To solve such interfacing problems, GBR42 supports configuration of the gateway with DDI Start number, Total DDI number, DDI Number of digits and Pilot Number; for two types of Networks.
 - Public ISDN
 - Private ISDN

How to select?

- The Public ISDN will require the 'Calling Party Number' in the "Call Set up message" when call is placed from TE Port which was originated from Mobile port. But since this number will not carry this 'CLI digits in the setup message, the call will be rejected by the Public Network.
- At the same time if it is placed on the ISDN PBX (Private Network), then the calling party number received on the source port will be transparently used by the TE port while placing call. Thus the call is successfully routed when the Network-Type is properly selected. Which number is sent when Public ISDN is selected?
 - The CLI number is checked if it is within the range of the programmed DDI numbers on the destination TE port.
 - It is sent as the same number without modification if it is within the range of programmed DDI numbers.
 - If it is not within the range of programmed DDI numbers the Pilot Number programmed for the TE port is sent as calling party number.

Following parameters are required for programming the table for selecting the Network Type:

- DDI Start Number
- Total DDI Numbers

- DDI Number of Digits

Total DDI Numbers:

- This is the total number of DDI numbers supported by NT/TE/Mobile. The Total DDI Numbers are from 0001 to 9999.

DDI Number of Digits:

- This is the number of digits in a DDI number. Suppose 200 DDI numbers are supported on a NT/TE/Mobile Trunk, then the Number of Digits for that Trunk should be programmed as 3. Suppose 10 DDI numbers are supported on another NT/TE/Mobile Trunk, then the number of Digits for that Trunk should be programmed as 2. The DDI Number of digits is from 0 to 4.

DDI Start Number:

- This is first number string of total DDI numbers programmed.

Pilot Number: This number will be sent if CLI number received is not within range of programmed DDI Numbers.

The Default Table programmed will be as shown below:

TE Port	Type of Network	Pilot Number	DDI Start Number	Total DDI Numbers	DDI No. of Digits
1	Public ISDN	Blank	Blank	100	2
2	Public ISDN	Blank	Blank	100	2

How to program?

Step 1: To enable/disable a TE port using command **401**.

Step 2: To assign a BRI hardware (physical) port to a TE logical port using command **402**.

Step 3: To set First digit wait timer using command **403**.

Step 4: To set Inter digit wait timer using command **404**.

Step 5: To program the ISDN Switch Variant for a TE port using command **405**.

Step 6: To program the OG Digit dialing method for TE port using command **406**.

Step 7: To program to initialize using SPID for the TE Port using command **407**.

-
- Step 8:** To program Overlap Receiving Timer for TE Port using command **409**.
- Step 9:** To program the Idle Code for the TE port using command **410**.
- Step 10:** To assign the type of network with TE port interfaced using command **411**.
- Step 11:** To program the pilot number for the TE port using command **412**.
- Step 12:** To program the start DDI number for the TE Port using command **413**.
- Step 13:** To program total DDI number for the TE Port using command **414**.
- Step 14:** To program DDI number of digits for the TE Port using command **415**.
- Step 15:** To allow/deny the incoming calls for TE port using command **416**.
- Step 16:** To enable/disable DID on TE Port using command **672**.
- Step 17:** Program called party TON for TE port using command **418**.
- Step 18:** Program called party NPI for TE port using command **419**.
- Step 19:** Program calling party TON for TE port using command **420**.
- Step 20:** Program calling party NPI for TE port using command **421**.
- Step 21:** Select the TEI Negotiation Mode for TE port using command **422**.
- Step 22:** Program the TEI Negotiation Value for the Fixed TEI Negotiation Mode using command **423**.

Step 1

Port Status (Enable/Disable)

This command is used to disable a TE port. Disabling TE port is required in cases when no calls are to be initiated or terminated on this port. If disabled, the caller gets error tone, when accessing the port.

Use following command to enable/disable a TE Port:

401-TE Port-Code-#*

Where,

TE Port is from 1 to 2.

Code	Meaning
0	Disable
1	Enable

By default, TE port is enabled.

Step 2

Use following command to assign a BRI hardware (Physical) port to a TE logical port:

402-TE Port-BRI Port-#*

Where,

TE port is from 1 to 2.

BRI Port is from 1 to 2.

By default, TE Port 1 and TE Port 2 are not assigned any Physical port. If you assign Physical Port to BRI TE port, jumper settings for that port shall be set to match TE Mode.

Step 3

First Digit Wait Timer-This timer signifies the time for which the system waits for first digit after the port is made OFF-Hook. On expiry of this timer, the fixed destination number is dialed out on the port.

Use following command to program first digit wait timer for TE port:

403-TE Port-First Digit Wait Timer-#*

Where,

TE Port is from 1 to 2.

First Digit wait timer is from 01 to 99 seconds.

By default, First Digit Wait Timer is 05 seconds.

Step 4

Inter Digit Wait Timer-This timer signifies the time between two digits dialed on the port. On expiry of this timer, the Gateway considers it to be an end of string and proceeds with the call processing logic.

Use the following command to program the inter digit wait timer for TE port:

404-TE Port-Inter Digit Wait Timer-#*

Where,

TE Port is from 1 to 2.

Inter Digit Wait Timer is from 01 to 99 seconds.

By default, Inter Digit Wait Timer is 05 seconds.

Step 5

Use following command to program the ISDN switch variant for a TE port:

405-TE Port-ISDN Switch Variant-#*

Where,

TE Port is from 1 to 2.

ISDN Switch Variant is 01 (ETSI_NET3).

By default, ISDN Switch Variant is '01'.

Step 6

The gateway supports two methods of digit dialing:

- Enbloc.
- Overlap.

Enbloc refers to sending/dialing in a single block after collecting all the dialed digits. Whereas, Overlap method refers to sending digits, immediately when user dials it. Most of the ISDN equipments use 'enbloc' dialing.

Use following command to program the OG digit dialing method for the TE port:

406-TE Port-Code-#*

TE is from 1 to 2.

Code	Meaning
1	Enbloc
2	Overlap

By default, OG Digit dialing method is '1'.

Step 7

This command is issued from SE mode only. The gateway will get initialized on issuing this command. On issuing this command, a non-voice call is made to the network with an INFORMATION message containing SPID IE. The Network responds with an INFORMATION message with Terminal Endpoint Identifier (IE) containing USID and TID. The USID and TID so received are stored in the memory of the system and subsequently used in each OG call made through the TE

port. If the network does not respond to the INFORMATION message within network response timer user will get error tone. If the network responds with the Endpoint Terminal identifier IE and if the received USID and TID are stored in the system, the system user will get Confirmation tone. SPID needs to be used manually as explained above.

Use following command to get SPID for TE port. (This command is required only if SPID is to be used. In India SPID is not used):

407-TE Port-SPID Number-#*

Where,

TE is from 1 to 2.

SPID Number is of 24 digits (0-9, *, #).

By default, SPID Number is Blank.

Using Jeeves for SPID:

When you program with Jeeves you can program 'SPID' in following table:

TE Port	SPID	USID	TID
1		Note1	Note1
2			

Note1:

- By clicking on 'Initialize', the SPID message will be sent by the respective TE port. No confirmation is expected by the Jeeves. You will see the USID and TID if required, by downloading the page.
- User will get only confirmation tone when command to display SPID or TID is applied. User will not get any display.

Step 8

Overlap Receiving Timer: This parameter is applicable only while receiving the called party number information in overlap receiving mode. It is not applicable for the port in overlap sending mode.

Use following command to program Overlap Receiving Timer for TE Port:

409-TE Port-Overlap Receiving Timer-#*

Where,

TE Port is from 1 to 2.

Overlap Receiving Timer is from 001 to 255 seconds.

By default, Overlap Receiving Timer is 15 seconds.

Step 9

Use following command to program the idle code for the TE port:

410-TE Port-Idle Code-#*

Where,

TE is from 1 to 2.

Idle Code is from 000 to 255 (Corresponding to 8 bits).

The binary equivalent of the programmed value (000 to 255) is sent on the channel to signify that the channel is idle (or unused). This setting depends on the network. Most commonly applicable values are 7F and FF (Binary equivalent is 0111 1111 and 1111 1111, decimal equivalent is 127 and 255).

By default Idle Code is 127 (7F).

Step 10

Use following command to assign the 'Type of Network' with which, the TE port is interfaced:

411-TE Port-Code-#*

Where,

TE Port is from 1 to 2.

Code	Meaning
1	Public ISDN
2	Private ISDN

By default, Type of Network is '1' for TE Port.

Note:

- The ISDN line subscribed from the telephone exchange is connected on the TE port.

Step 11

Use following command to program the DDI Pilot Number for the TE port:

412-TE Port-DDI Pilot Number-#*

Where,

TE Port is from 1 to 2.

DDI Pilot Number is number string of 16 digits maximum, with digits 0-9.

By default, Pilot Number for the TE port is Blank.

Step 12

Use following command to program the Start DDI Number for the TE port:

413-TE Port-DDI Start Number-#*

Where,

TE Port is from 1 to 2.

DDI Start Number is a number string of 16 digits maximum, with digits 0-9.

By default, Start DDI Number for the TE port is Blank.

Step 13

Use following command to program the Total DDI Number for the TE port:

414-TE Port-Total DDI Number-#*

Where,

TE Port is from 1 to 2.

Total DDI Number is from 0001 to 9999, with 4-digits Maximum.

By default, Total DDI Number for the TE Port is 0100.

Step 14

Use following command to program the DDI Number of digits for the TE port:

415-TE Port-DDI Number of Digits-#*

Where,

Total DDI Number of digits is from 0 to 4.

By default, DDI Number of Digits for the TE Port is 2.

Step 15

- This gives option for allowing or denying the Incoming calls on this port.
- If this option is set to “Deny”, the port can not be used as source port as all the call originating on this port will get rejected.
- If this option is set to “Allow”, the port can be used as source port. All the calls originating on this port will get routed based on the programming.
- If this port is ‘Destination Port’ this command is not applicable.

Use following command to allow/deny the Incoming Calls for TE port:

416-TE Port-Code-#*

Where,

TE Port is from 1 to 2.

Code	Meaning
0	Deny
1	Allow

By default = 1, Port must be 'enabled' to allow/deny IC Calls.

Step 16

Use the following command to enable/disable DID on TE port:

672-TE Port-Code-#*

Where,

TE Port is from 1 to 2.

Code	Meaning
0	Disable
1	Enable

By default, DID on TE Port is 0.

Step 17

Use following command to program 'Called Party TON' for TE port:

418-TE Port-Called Party TON-#*

Where,

TE Port is from 1 to 2.

Called Party TON is from 1 to 7.

Called Party TON	Meaning
1	Unknown
2	International Number
3	National Number
4	N/w Specific Number
5	Subscriber Number
6	Abbreviated Number
7	Reserved Number

By default, Called Party TON is 'Unknown'.

Step 18

Use following command to program 'Called Party NPI' for TE port:

419-TE Port-Called Party NPI-#*

Where,

TE Port is from 1 to 2.

Called Party NPI is from 1 to 7.

Called Party NPI	Meaning
1	Unknown
2	ISDN Numbering
3	Data Numbering
4	Telex Numbering
5	National Numbering
6	Private
7	Reserved

By default, 'Called Party NPI' is 'ISDN Numbering'.

Step 19

Use following command to program 'Calling Party TON' for TE port:

420-TE Port-Calling Party TON-#*

Where,

TE Port is from 1 to 2.

Calling Party TON is from 1 to 7.

Calling Party TON	Meaning
1	Unknown
2	International Number
3	National Number
4	N/w Specific Number
5	Subscriber Number
6	Abbreviated Number
7	Reserved Number

By default, Calling Party TON is 'Unknown'.

Step 20

Use following command to program 'Calling Party NPI' for TE port:

421-TE Port-Calling Party NPI-#*

Where,

TE Port is from 1 to 2.

Calling Party NPI is from 1 to 7.

Calling Party NPI	Meaning
1	Unknown
2	ISDN Numbering
3	Data Numbering
4	Telex Numbering
5	National Numbering
6	Private
7	Reserved

By default, Calling Party NPI is 'ISDN Numbering'.

Step 21

TEI Negotiation Mode

- To integrate the Simado GBR42 with the specific PBX Type (e.g. Nortel PBX), the parameter TEI Negotiation mode, should be 'fixed' instead of 'automatic'. Hence the GBR42 supports both options: Automatic and Fixed. If it is selected as 'Fixed' its value should be programmed.

Use following command to select TEI Negotiation on the TE port:

422-TE Port-TEI Negotiation Mode-#*

Where,

TE Port is from 1 to 2.

TEI Negotiation Mode	Meaning
1	Automatic
2	Fixed

By default, TEI Negotiation Mode is 'Automatic'.

Note:

- GBR42 will get reset when TEI Negotiation Mode is changed for any port.

Step 22

TEI Negotiation Value

- Program the value if the TEI Negotiation Mode is selected as 'Fixed'.

Use following command to program TEI Negotiation value for the Fixed TEI Negotiation Mode:

423-TE Port-Value-#*

Where,

TE Port is from 1 to 2.

Value is from 00 to 63.

By default, TEI Negotiation value is 00 for both TE ports.

Note:

- GBR42 will get reset when TEI value for fixed mode is changed for any port.
- When BRI port of GBR42 is configured as BRI-TE mode, the TEI value programmed for it should match with the TEI value expected by the NT equipment at other end.

Important Points:

- TON is the Type Of Number which is used to identify the dialing structure, used by ISDN service provider and NPI is the 'Numbering Plan Identifier' used to identify the type of network, used by these services.
- **Relax Delay Timer:** It is the time between end of one call and beginning of another call on a port. This timer is approx 1 sec. Because of this, user should wait till the port to be idle, so that a new outgoing call can be initiated from the same port.

Relevant Topics:

1. Call Proceeding Tone 49
2. Configuring the System 16
3. NT Port Parameters 106
4. Remote Programming 118

=X=X=

Time Table

What's this?

- A user may prefer to initiate a call from particular phone port at a particular timezone during a day. He may need to receive his trunk or mobile call during morning hour on phone 1 and during afternoon hours on phone 2.
- These examples highlight the need for the system to behave differently depending on the time of the day. The SIMADO GBR42 offers a very flexible programming for different time zones. A day can be divided in, four timezones. Such a schedule of a day is called a Time Table. The gateway offers maximum of 8 time tables.
- Different Routing Type and Routing Group can be selected for different time zones, which are defined by the time table, assigned to the port.
- Time table can be assigned to each NT/TE/Mobile port.

How to program?

Step 1: To program start and stop time for timezone in a time table using command **105**.

Step 2: To assign a time table to a Mobile port using command **106**.

Step 3: To assign a time table to a TE port using command **107**.

Step 4: To assign a time table to a NT port using command **108**.

Step 1

Use following command to program start and stop time for timezones in a time table:

105-Time Table-Time Zone-Start Time-End Time-#*

Where,

Time Table is from 1 to 8.

Time Zone is from 1 to 4.

Start time is in form of HH:MM.

End time is in for of HH:MM.

HH is from 00 to 23.

MM is from 00 to 59.

Default Time Table is given below:

Time Table	Time Zone1				Time Zone4			
	Start Time		End Time			Start Time		End Time	
	Hr	Min	Hr	Min	Hr	Min	Hr	Min
1	00	00	23	59	00	00	23	59
2	00	00	23	59	00	00	23	59
3	00	00	23	59	00	00	23	59
4	00	00	23	59	00	00	23	59
5	00	00	23	59	00	00	23	59
6	00	00	23	59	00	00	23	59
7	00	00	23	59	00	00	23	59
8	00	00	23	59	00	00	23	59

Step 2

Use following command to assign time table to the mobile port:

106-Mobile Port-Time Table-#*

Where,

Mobile Port is from 1 to 4.

Time Table is from 1 to 8.

By default, Time Table 1 is assigned to all the Mobile Port.

Step 3

Use following command to assign time table to the TE port:

107-TE Port-Time Table-#*

Where,

TE Port is from 1 to 2.

Time Table is from 1 to 8.

By default, Time Table 1 is assigned to all the TE port.

Step 4

Use following command to assign time table to the NT port:

108-NT Port-Time Table-#*

Where,

NT Port is from 1 to 2.

Time Table is from 1 to 8.

By default, Time Table 1 is assigned to all the NT Port.

Example:

A user wants to dial a number from his phone port number 1. He wants that system should allow to dial only during 09:00 to 13:00 AM. This can be programmed by following steps.

- 101-DD-MM-YYYY-#*** (Set system time with RTC)
- 105-2-1-0900-1300-#*** (Timetable number 2, Timezone 1)
- 105-2-2-1301-0859-#*** (Timetable number 2, Timezone 2)
- 108-1-2-#*** (Assign Timetable 2 to NT1)
- 659-1-3-#*** (Routing Type 'Dialed Number Based' for Timezone 1)

Relevant Topics:

1. Routing Type 131
2. Routing Group 124
3. Real Time Clock 116

=X=X=

Section 3: Appendices

Appendix A : Technical Specifications

Configuration and Capacity:

	Application	Qty.
Maximum User Ports	User Interface Connectivity	6
Maximum GSM Ports	GSM Network	4
Maximum BRI Ports	ISDN BRI Line Connectivity	2
Antenna Port	Antenna Connection	1
COM Port-RS232C	Computer Connectivity	1

GSM Interface

GSM Quad Band	: GSM 850, EGSM 900, DCS 1800, PCS 1900, programmable frequency band.
Compliant	: ETSI GSM Phase2+
SIM Card	: One SIM per GSM Channel
RF Transmission Power	: 2W in case of 850/900 MHz band, 1W in case of 1800/1900 MHz band
RF Sensitivity	: Better than -106dBm

BRI Port Parameters

Channel	: 2B+D
Personality	: NT or TE (User Programmable)
Signalling	: ITU I.430, Q.921, Q.931
Interface	: S/T interface, Point-to-Point and Point-to-Multipoint
Connection	: RJ45 (120Ω)
Call Progress Tones	: Selectable as per country

Antenna Parameters

Type of antenna	: Dipole/Whip Fixed/Omni Directional Antenna, Roof-Top antenna with flexible cable of 3mtrs. is optional
Antenna Gain	: 2.5dBi
Antenna Connector	: SMA (Female), 50Ω Impedance

Clock Synchronization

Source	: Internal or timing Derived
External Clock	: As per ITU (CCITT) Rec. G.703

Matrix

Impedance of Ext. Clock : 120Ω
Default Clock Operation : Internal

Interface

Serial Port (RS232C) : DB9 Connector
Transmission Rate : 19200bps

Security

Password : SE Password
SIM : SIM PIN, PUK, IMEI

LED Indications

Number of LEDs : 9 (4 for Mobile Ports, 4 for BRI Channels and 1 for Power 'ON')
Power Supply Status : Power ON
Network Status : Present, Absent, SIM PIN Faulty, PUK required
GSM Module Status : Module Fail

Power Supply : 12 VDC, 2 Amp.
Power Consumption : 10W (Typical)

Environmental Conditions

Operating Temperature : -10°C to +50°C (14°F to 122°F)
Store Temperature : -40°C to +85°C (-40°F to 185°F)
Operating Humidity : 20-70%
Storage Humidity : Max. 95% (Non Condensing) at 40°C (104°F)
Recommended : Air Condition, UPS

Packaging

Dimension (WxHxD) : 155x220x50 mm (6.10x8.66x1.97 Inch)
Unit Weight : 1.8Kg (3.97lbs) Approx.
Shipping Weight : 3.45Kg (7.61lbs) Approx.
Installation Mounting : Standalone and Table Top

=X=X=

Appendix B : System Commands

Chapter Name	Programming Commands
Allowed and Denied Lists	
To ena/dis allowed/denied no. feature for Mobile port	<i>221-Mobile Port-Code-#*</i>
To assign an allowed number list to a Mobile port	<i>222-Mobile Port-List Number-#*</i>
To assign a denied number list to a Mobile port	<i>223-Mobile Port-List Number-#*</i>
To ena/dis allowed/denied no. feature for TE port	<i>224-TE Port-Code-#*</i>
To assign an allowed number list to a TE port	<i>225-TE Port-List Number-#*</i>
To assign a denied number list to a TE port	<i>226-TE Port-List Number-#*</i>
To ena/dis allowed/denied no. feature for NT port	<i>227-NT Port-Code-#*</i>
To assign an allowed number list to a NT port	<i>228-NT Port-List Number-#*</i>
To assign a denied number list to a NT port	<i>229-NT Port-List Number-#*</i>
Automatic Number Translation	
To enable/disable ANT feature for Mobile port	<i>621-Mobile Port-Code-#*</i>
To assign a No. list (Dialed No. String) to Mobile port	<i>622-Mobile Port-List Number-#*</i>
To assign a No. list (Substitute No. String) to Mob. port	<i>623-Mobile Port-List Number-#*</i>
To enable/disable ANT feature for TE port	<i>624-TE Port-Code-#*</i>
To assign a No. list (Dialed No. String) to TE port	<i>625-TE Port-List Number-#*</i>
To assign a No. list (Substitute No. String) to TE port	<i>626-TE Port-List Number-#*</i>
To enable/disable ANT feature for NT port	<i>627-NT Port-Code-#*</i>
To assign a No. list (Dialed No. String) to NT port	<i>628-NT Port-List Number-#*</i>
To assign a No. list (Substitute No. String) to NT port	<i>629-NT Port-List Number-#*</i>
Call Detail Recording	
To start/stop the printing of CDR	<i>171-Code-#*</i>
Set filter to print calls terminated from TE port	<i>172-Code-#*</i>
Set filter to print all calls terminated from TE ports	<i>173-TE Port-TE Port-#*</i>
Disable filter to print all calls terminated from TE ports	<i>173-#*</i>
Set filter to print calls terminated from NT ports	<i>174-Code-#*</i>
Set filter to print all calls terminated from NT ports	<i>175-NT Port-NT Port-#*</i>
Disable filter to print all calls terminated from NT ports	<i>175-#*</i>
Set filter to print calls terminated from Mobile port	<i>176-Code-#*</i>
Set filter to print all calls terminated from Mobile ports	<i>177-Mobile Port-Mobile Port-#*</i>
Disable filter to print all calls terminated from Mobile ports	<i>177-#*</i>
Set filter to print calls originated from TE port	<i>178-Code-#*</i>
Set filter to print all calls originated from TE ports	<i>179-TE Port-TE Port-#*</i>
Disable filter to print all calls originated from TE ports	<i>179-#*</i>
Set filter to print calls originated from NT ports	<i>180-Code-#*</i>
Set filter to print all calls originated from NT ports	<i>181-NT Port-NT Port-#*</i>
Disable filter to print all calls originated from NT ports	<i>181-#*</i>
Set filter to print calls originated from Mobile port	<i>182-Code-#*</i>
Set filter to print all calls originated from Mobile ports	<i>183-Mobile Port-Mobile Port-#*</i>
Disable filter to print all calls originated from Mobile ports	<i>183-#*</i>
Set filter to print all calls from to Date	<i>184-DD-MM-YYYY-DD-MM-YYYY-#*</i>
Set filter to print all calls between Time	<i>185-HH-MM-HH-MM-#*</i>
Set filter to print all calls mat. the no. list (called)	<i>186-Called Party Number List-#*</i>
Set filter to print all calls mat. the no. list (calling)	<i>187-Calling Party Number List-#*</i>
Set filter to print all calls duration more than spec.	<i>188-Seconds-#*</i>
Set default all CDR filters	<i>189-#*</i>
To clear the CDR Buffer	<i>190-Reverse SE Password-#*</i>

Matrix

Call Duration Control

To enable/disable CDC

*191-Code-#**

To program the CDC timer

*192-CDC Timer-#**

Call Proceeding Tone

To set Call Proceeding Tone for Mobile port

*307-Mobile Port-Code-#**

To assign a call proceeding tone to the TE Port

*408-TE Port-Code-#**

Call Progress Tone

To select the country for CPTG

*213-Code-#**

Calling Party Number Based Routing

To program the CLI number string

*131-CLI Rou. Index-CLI No. Str-#**

To clear CLI number string

*131-CLI Routing Index-#**

To program the Routing Group for a CLI number

*132-CLI Routing Index-RG-#**

To program the changed called number flag

*133-CLI Routing Index-Code-#**

To program new call no. at an index in CLI routing table

*134-CLI RT Index-New Called No.-#**

To clear new call no. at an index in CLI routing table

*134-CLI Routing Table Index-#**

To clear entire CLI routing Table

*135-#**

Clock Synchronization

To assign the clock priority to clock source

*215-Priority-Clock Source-#**

Communication Port

To enable/disable event logging process

*214-Code-#**

Daylight Saving Time Adjustment

To select DST Forward Time Adjustment Type

*111-DST Forward Time Adjustment-#**

To select DST Forward parameter for Day-Month wise

*112-Ord.-Day-Mon-HH-MM-HH-MM-#**

To select DST Forward parameter for Date-Month wise

*113-Date-Month-HH-MM-HH-MM-#**

To select DST Backward Time Adjustment Type

*114-DST Backward Time Adj.-#**

To select DST Backward parameter for Day-Month wise

*115-Ord.-Day-Mon-HH-MM-HH-MM-#**

To select DST Backward parameter for Date-Month wise

*116-Date-Month-HH-MM-HH-MM-#**

Default the Configuration

To assign default configuration to the system

*201-Reverse SE Password-#**

Dialed Number Based Routing

To program prefix string in dialed no. based table

*151-No. Str. Table Index-No. String-#**

To clear the prefix string in the dialed no. based table

*151-No. String Table Index-#**

To program routing group in dialed no. based table

*152-No. String Table Index-RG-#**

To program changed called number flag in the table

*153-No. String Table Index-Code-#**

To program new called number at an index in the table

*154-No. ST Index-New Called No.-#**

To clear called number at an Index in the table

*154-No. ST Index-#**

To clear the entire dialed number string table

*155-#**

Emergency Number Dialing

To program Emergency No. in Emergency No. table

*731-Index-Emergency Number-#**

To clear Emergency No. from Emergency No. table

*731-Index-#**

To program routing group for Emergency number

*732-Index-Routing Group-#**

Fixed Dialing

To enable/disable fixed dialing on a Mobile Port

*631-Mobile Port-Code-#**

To program the destination number for the Mobile Port

*632-Mobile Port-Number String-#**

To enable/disable fixed dialing on a TE Port

*633-TE Port-Code-#**

To program the destination number for the TE Port	634-TE Port-Number String-#*
To enable/disable fixed dialing on a NT Port	635-NT Port-Code-#*
To program the destination number for the NT Port	636-NT Port-Number String-#*
International Mobile Equipment Identity	
To display the IMEI number of the GSM module (For Jeeves Only)	715-Mobile Port-#*
Mobile Port Parameters	
To enable/disable a Mobile Port	301-Mobile Port-Code-#*
To program the receive gain of a Mobile Port	302-Mobile Port-Receive Gain-#*
To program the transmit gain of a Mobile Port	303-Mobile Port-Transmit Gain-#*
To set First digit wait timer to the Mobile port	304-Mob. Port-First Digit Wait Timer-#*
To set Inter digit wait timer to the Mobile Port	305-Mob. Port-Inter Digit Wait Timer-#*
To allow/deny Incoming calls for Mobile port	308-Mobile Port-Code-#*
To program frequency band for mobile port	309-Mobile-Mobile Frequency Band
To request the signal strength for mobile port	311-Mobile Port-#*
To enable/disable DID on Mobile port	671-Mobile Port-Code-#*
Network Selection	
To program network selection mode for the mobile port	721-Mobile Port-Code-#*
To prog.N/w Opr. code in priority for mobile port	722-Mob. Port-Priority-N/w Opr. Code-#*
To clear network operator code for mobile port	722-Mobile Port-Priority Index-#*
NT Port Parameters	
To enable/disable a NT Port	501-NT Port-Code-#*
To assign BRI hardware (Phy.) port to NT logical port	502-NT Port-BRI Port-#*
To program Inter digit wait timer for NT port	504-NT Port-Inter Digit Wait Timer-#*
To program the ISDN Switch Variant for a NT Port	505-NT Port-ISDN Switch Variant-#*
To program overlap receiving timer for NT port	506-NT Port-Overlap Rec. Timer-#*
To program the Idle channel code for the NT port	510-NT Port-Idle Code-#*
To allow/deny incoming calls for NT port	511-NT Port-Code-#*
To program Called Party TON for NT port	513-NT Port-Called Party TON-#*
To program Called Party NPI for NT port	514-NT Port-Called Party NPI-#*
To program Calling Party TON for NT port	515-NT Port-Calling Party TON-#*
To program Calling Party NPI for NT port	516-NT Port-Calling Party NPI-#*
To select TEI Negotiation on the NT port	517-NT Port-TEI Negotiation Mode-#*
To program TEI Neg. value for the fixed TEI Neg. Mode	518-NT Port-Value-#*
Number Lists	
To program a No. string in a location index in No. List	121-List No.-Location Ind.-No. String-#*
To clear the location in the number list	121-List Number-Location Index-#*
To clear all the locations in the number list	122-List Number-#*
Programming the System	
To change the SE password	211-New SE Password-#*
Real Time Clock (RTC)	
To program the current date	101-DD-MM-YYYY-#*
To program the Day of the Week	102-Day-#*
To program the system time	103-HH-MM-SS-#*
Returned Calls to Original Callers	
To enable/dis. RCOC Busy dest. on Mobile port	601-Mobile Port-Code-#*
To enable/dis RCOC No Resp. dest. on Mobile port	602-Mobile Port-Code-#*

Matrix

To enable/dis. RCOG for Speech Dest. on Mobile port
To program to record delete timer
To clear RCOG table

603-Mobile Port-Code-#*
610-Record Delete Timer-#*
611-#*

Routing Group

To program a routing group table
To assign member selection method for RG
To assign a routing group to a Mobile port for TZ1
To assign a routing group to a Mobile port for TZ2
To assign a routing group to a Mobile port for TZ3
To assign a routing group to a Mobile port for TZ4
To assign a routing group to a TE port for TZ1
To assign a routing group to a TE port for TZ2
To assign a routing group to a TE port for TZ3
To assign a routing group to a TE port for TZ4
To assign a routing group to a NT port for TZ1
To assign a routing group to a NT port for TZ2
To assign a routing group to a NT port for TZ3
To assign a routing group to a NT port for TZ4

161-RG-Mem.Index-Port Type-Port No-#*
162-RG-Member Sel. Method-#*
681-Mobile Port-Routing Group-#*
682-Mobile Port-Routing Group-#*
683-Mobile Port-Routing Group-#*
684-Mobile Port-Routing Group-#*
685-TE Port-Routing Group-#*
686-TE Port-Routing Group-#*
687-TE Port-Routing Group-#*
688-TE Port-Routing Group-#*
689-NT Port-Routing Group-#*
690-NT Port-Routing Group-#*
691-NT Port-Routing Group-#*
692-NT Port-Routing Group-#*

Routing Type

To program a routing type for the Mobile port for TZ1
To program a routing type for the Mobile port for TZ2
To program a routing type for the Mobile port for TZ3
To program a routing type for the Mobile port for TZ4
To program a routing type for the TE port for TZ1
To program a routing type for the TE port for TZ2
To program a routing type for the TE port for TZ3
To program a routing type for the TE port for TZ4
To program a routing type for the NT port for TZ1
To program a routing type for the NT port for TZ2
To program a routing type for the NT port for TZ3
To program a routing type for the NT port for TZ4

651-Mobile Port-Routing Type-#*
652-Mobile Port-Routing Type-#*
653-Mobile Port-Routing Type-#*
654-Mobile Port-Routing Type-#*
655-TE Port-Routing Type-#*
656-TE Port-Routing Type-#*
657-TE Port-Routing Type-#*
658-TE Port-Routing Type-#*
659-NT Port-Routing Type-#*
660-NT Port-Routing Type-#*
661-NT Port-Routing Type-#*
662-NT Port-Routing Type-#*

SIM PIN

To change the SIM PIN

712-Mobile Port-New SIM PIN-#*

Software Version/Revision Display

The Software Version/Revision of the System

212-#* (For Jeeves Only)

System Event Log

To enable/disable event logging for call events
To select the Type of event logging for the Mobile port
To enable/disable type of event logging for BRI-TE port
To enable/disable type of event logging for BRI-NT port

231-Code
306-Mobile Port-Code
417-TE Port-Level-Code-#*
512-NT Port-Level-Code-#*

System Parameters

To select A-law and mu-Law for the gateway
To conf. to strip the + or not from the received party No.
To prog. the repl.str. to be used to replace + in the CLI
To use # as end of dialing digit

109-PCM Selection-#*
216-Code-#*
217-#*
141-Code-#*

TE Port Parameters

To enable/disable a TE Port

401-TE Port-Code-#*

To assign hardware port to the TE port	402-TE Port-BRI Port-#*
To program First Digit Wait Timer for TE Port	403-TE Port-First Digit Wait Timer-#*
To program the Inter Digit Wait Timer for TE Port	404-TE Port-Inter Digit Wait Timer-#*
To program the ISDN Switch Variant for a TE Port	405-TE Port-ISDN Switch Variant-#*
To prg. the OG Digit dialing method for the TE port	406-TE Port-Code-#*
To initialize, if SPID is used	407-TE Port-SPID Number-#*
To program overlap receiving timer for TE port	409-TE Port-Overlap Rec. Timer-#*
To assign an idle channel code for TE logical Port	410-TE Port-Idle Code-#*
To assign the Type of network to TE Port	411-TE Port-Code-#*
To program the DDI pilot number for the TE Port	412-TE Port-DDI Pilot Number-#*
To program the Start DDI Number for the TE Port	413-TE Port-DDI Start Number-#*
To program the total DDI Number for the TE Port	414-TE Port-Total DDI Number-#*
To program the DDI Number of Digits for the TE Port	415-TE Port-DDI Number of Digits-#*
To allow/deny incoming calls for the TE Port	416-TE Port-Code-#*
To enable/disable DID on TE port	672-TE Port-Code-#*
To program Called Party TON for TE port	418-TE Port-Called Party TON-#*
To program Called Party NPI for TE port	419-TE Port-Called Party NPI-#*
To program Calling Party TON for TE port	420-TE Port-Calling Party TON-#*
To program Calling Party NPI for TE port	421-TE Port-Calling Party NPI-#*
To select TEI Negotiation on the TE port	422-TE Port-TEI Negotiation Mode-#*
To program TEI Neg. value for the fixed TEI Neg. Mode	423-TE Port-Value-#*

Time Table

To program start/stop time for TZ in time table	105-Time Table-TZ-Start Time-End Time-#*
To assign time table to the Mobile port	106-Mobile Port-Time Table-#*
To assign time table to the TE port	107-TE Port-Time Table-#*
To assign time table to the NT port	108-NT Port-Time Table-#*

Appendix C: Regulatory Information

DECLARATION OF CONFORMITY EC Directives



We, Matrix Telecom Private Limited, hereby declare that the product listed below, to which this Declaration of Conformity relates, is in the conformity with Directives, Standards and other Normative Documents as listed.

- 1995/5/EC, Radio Equipment and Telecommunications Terminal Equipment Directive (R&TTE)
- 73/23/EEC, Low Voltage Directive (LVD)
- 89/336/EEC, Electromagnetic Compatibility Directive (EMC)

Type of Product : GSM Gateway
Product Name : Simado GBR42
Model Number : M 159
Intended Use : External Communication

1. STANDARDS:

EMI/EMC	: CISPR22	IEC 61000-3-2	IEC 61000-3-3
	: IEC 61000-4-2	IEC 61000-4-3	IEC 61000-4-4
	: IEC 61000-4-5	IEC 61000-4-6	IEC 61000-4-8
	: IEC 61000-4-11		

LVD, Safety : IEC 60950 3rd Edition (1999)

2. NORMATIVE DOCUMENTS AND REFERENCES:

Test reports are available at:

Matrix Telecom Private Limited, 394, GIDC, Makarpura, Vadodara -390 010, India

User Information:

User information on intended use, interface compatibility, system facilities and features are laid down in the following documentation

- Simado GBR42 System Manual

Date : 04th Aug 2007

Place : Vadodara, India

Ganesh Jivani
(Director)

Matrix Telecom Private Limited, Vadodara



Declaration of Conformity (RoHS Declaration)

We, Matrix Telecom Private Limited hereby declare that the product listed below, to which this Declaration of Conformity relates, is in the conformity with the requirement of the following European Union Directive for RoHS compliance:

Document No.	Title	Edition/Date of Issue
EN 2002/95/EC	Restriction of Hazardous Substances	27 January 2003

Type of Equipment : GSM Gateway
Equipment Name : Simado
Equipment Models : GBR42

Manufacturer's Name : Matrix Telecom Private Limited
Address : 39 – GIDC
Waghodia – 391 760
Dist: Vadodara, India

Additional Information:

The text of EU Directive 2002/95/EC may be found at the following website:
http://europa.eu.int/eur-lex/pri/en/oj/dat/2003/l_037/l_03720030213en00190023.pdf

Date : 15th May 2007
Place : Vadodara, India

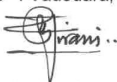

Ganesh Jivani
(Director)
Matrix Telecom Private Limited



Index

A

A Law-See [System Parameters](#) 143

B

Baud Rate-See [Communication Port](#) 65

C

CDC Timer-See [Call Detail Recording](#) 43

CDR Report-See [Communication Port](#) 65

Changed Called Number-See [Calling Party Number Based Routing](#) 59

Clear CDR Buffer-See [Call Detail Recording](#) 43

Clear Emergency Number-See [Emergency Number Dialing](#) 78

CLI Routing Table-See [Calling Party Number Based Routing](#) 59

Clock Source-See [Clock Synchronization](#) 63

Country-See [Call Progress Tones](#) 56

D

Date-Month Wise-See [Daylight Saving Time Adjustment](#) 67

Debug-See [Communication Port](#) 65

Default All CDR Filter-See [Call Detail Recording](#) 43

Dialed Number List-See [Automatic Number Translation](#) 38

E

Enable/Disable Fixed Dialing-See [Fixed Dialing](#) 82

End of Dialing Digits-See [System Parameters](#) 143

F

Feature Tone-See [Call Progress Tones](#) 56

First Digit Wait Timer-See [Mobile Port Parameters](#) 96

Fixed Destination Number-See [Fixed Dialing](#) 82

Frequency Band-See [Mobile Port Parameters](#) 96

G

Gateway Tone-See [Call Progress Tones](#) 56

GSM Engine-See [Emergency Number Dialing](#) 78

GSM Module-See [International Mobile Equipment Identity \(IMEI\)](#) 85

GSM Network Tone-See [Call Progress Tones](#) 56

H

Hardware Default-See [Default the Configuration](#) 72

I

Inter Digit Wait Timer-See [Mobile Port Parameters](#) 96

ISDN Network Tone-See [TE Port Parameters](#) 146

J**K****L**

LCR-See [Dialed Number Based Routing](#) 73

M

MCC-MNC-See [Network Selection](#) 102

Mu Law-See [System Parameters](#) 143

N

Network Operator Code-See [Network Selection](#) 102

Network Response Timer-See [Mobile Port Parameters](#) 96

New Called Number-See [Calling Party Number Based Routing](#) 59

O

Ordinal-See [Daylight Saving Time Adjustment](#) 67

Originating Port-See [Call Processing in SIMADO GBR42](#) 52

Overlap Receiving Timer-See [NT Port Parameters](#) 106

P

Priority-See [Network Selection](#) 102

Q**R**

Receive Gain-See [Mobile Port Parameters](#) 96

Replacement String-See [System Parameters](#) 143

Report Generation-See [Call Detail Recording](#) 43

Reverse SE Password-See [Default the Configuration](#) 72

S

Signal Strength-See [Mobile Port Parameters](#) 96

Substitute Number List-See [Automatic Number Translation](#) 38

T

TEI Negotiation Mode-See [NT Port Parameters](#) 106, [TE Port Parameters](#) 146

TEI Negotiation Value-See [NT Port Parameters](#) 106, [TE Port Parameters](#) 146

Tone Specifications-See [Call Progress Tones](#) 56

Transmit Gain-See [Mobile Port Parameters](#) 96

U

V

W

Week-Day-Month Wise-See [Daylight Saving Time Adjustment](#) 67

X

Y

Z

=X=X=